

■ Green Up the Roof!

DIADEM®

ROOF X C

EN Permanent anchor devices
DE Permanente Anschlagseinrichtungen
FR Système permanent de protection contre les chutes de hauteur
IT Sistema di ancoraggio anticaduta
ES Dispositivos de anclaje permanentes
HU Leesés elleni kikötési rendszer

EN Installation Guide
DE Montageanleitung
FR Guide d'installation
IT Manuale di installazione
ES Instrucciones de montaje
HU Beépítési útmutató

Single

A

B



Glide

C

D



EN 795:2012 C
CEN/TS 16415:2013





EN Safety instructions

General information

- The system may only be installed by appropriately trained, competent professionals who are familiar with the safety system.
- The installer of the system must be familiar and comply with the local, and labour safety regulations.
- The plan of the safety system (or a sketch of the rooftop) must be available at the access point to the roof safety system.
- On slanted roofs, the proper snow-catching features must be added to prevent ice or snow from causing damage in the system while sliding from the roof surface.

Safe installation

- Stainless steel may not come into contact with sanding dust or steel tools, as this can lead to corrosion.
- Proper fastening of the safety system must be documented with fastening reports and photos of the respective circumstances of installation.
- The installer must ensure that the substructure is appropriate for the fastening of the anchoring materials. In case of doubt, consult a structural engineer.
- The distance of the safety system from the roof edge is to be defined according to local regulations standards and depending on roof geometry.

DE Sicherheitshinweise

Allgemeine Informationen

- Die Permanenten Anschlageneinrichtungen dürfen nur von ausgebildeten, fach- und sachkundigen, und mit den Absturzsicherungen vertrauten Personen montiert werden.
- Der Monteur der Absturzsicherungen muss die vor Ort gültigen Vorschriften und Verordnungen der Unfallverhütung, sowie des Arbeitsschutzes kennen, berücksichtigen und einhalten.
- Beim Zugang zu den Absturzsicherungen sind die Positionen der Absturzsicherungen durch Pläne (z.B. Skizze der Dachaufsicht) zu dokumentieren.
- Bei geneigten Dachflächen muss durch geeignete Schneefangvorrichtungen das Abrutschen von Schnee (Eis, Schnee) verhindert werden, damit die Absturzsicherungen nicht beschädigt werden.

Sichere Montage

- Edelstahl darf nicht mit Schleifstaub oder Stahlwerkzeugen in Berührung kommen. Dies kann zu Korrosionsbildung führen.
- Die fachgerechte Befestigung der Absturzsicherungen am Bauwerk muss durch Drehmomentkontrolle und Fotos der jeweiligen Einbausituation dokumentiert werden.
- Der Monteur muss sicherstellen, dass der Untergrund für die Befestigung der Absturzsicherungen geeignet ist. Im Zweifelsfall ist ein Statiker hinzu zu ziehen.
- Die Abstände der Absturzsicherungen zur Absturzkante sind gemäss den vor Ort geltenden Vorschriften, Normen und in Abhängigkeit von der Dachgeometrie zu wählen.

FR Consignes de sécurité

Informations Générales

- Le système permanent de sécurité ne doit être monté que par des personnes formées, compétentes / expérimentées et connaissant bien le système.
- Le monteur doit connaître les règles de sécurité et les directives en vigueur sur le site et il faut les respecter.
- Lors de l'accès au système de sécurité, le maître d'œuvre déterminera au moyen de plans, les positions des systèmes de sécurité (par ex. croquis de la partie supérieure de la toiture).
- Dans le cas de toits inclinés, il faut éviter les glissements de neige ou de glace au moyen de dispositifs de retenue appropriés.

Pour un montage en toute sécurité

- L'acier inoxydable ne doit pas entrer en contact avec de la poussière de meulage ni avec des outils en acier, ceci pouvant entraîner une corrosion ultérieure.
- La fixation appropriée du système de sécurité sur un ouvrage doit être documentée par un protocole et un dossier photographique illustrant chaque cas de montage.
- Les monteurs doivent s'assurer que le support convient à la fixation du système d'ancrage. En cas de doute, il faut faire appel à un ingénieur B.T.P.
- La distance de bord du toit doit être déterminée dans les règles de l'art conformément aux directives en vigueur.

IT Note di Sicurezza

Informazioni generali

- I sistemi anticaduta possono essere montati soltanto da persone che hanno conoscenza di questi sistemi, e sono qualificate e esperte in questo settore.
- Il montatore dei sistemi anticaduta deve conoscere i regolamenti e le prescrizioni locali riguardanti la prevenzione degli infortuni e sicurezza sul lavoro e aderirli in modo stretto.
- Quando si accede alle sicurezze anticaduta, le posizioni delle stesse devono essere documentate da piani (ad esempio, schizzo del controllo tetto).
- Con tetti inclinati deve essere impedito con sistemi appropriati che la neve o ghiaccio non possano scivolare giù danneggiando i sistemi anticaduta.

Montaggio sicuro

- L'acciaio inox non può venire in contatto con trucioli o con attrezzature in acciaio, potrebbe causare corrosione.
- Il fissaggio appropriato dei sistemi anticaduta deve essere documentato tramite verbali di fissaggio e fotografie della situazione attuale del montaggio.
- Il montatore deve accertarsi che il sottofondo sia adatto al fissaggio dei sistemi anticaduta. In caso di dubbio consultare un ingegnere strutturale.
- Scegliere le distanze dei sistemi di sicurezza rispetto al bordo del tetto secondo le norme valide localmente e tenendo conto della geometria del tetto.

ES Indicaciones de seguridad

Información general

- Los dispositivos de anclaje permanentes solo deben montarse por personas formadas, especializadas, profesionales y que estén familiarizadas con los dispositivos de protección contra caídas.
- El montador de los dispositivos de protección contra caídas debe conocer, observar y respetar las normas y disposiciones aplicables localmente de prevención de accidentes y de protección laboral.
- Al punto de acceso a los dispositivos de protección contra caídas deben documentarse las posiciones de los dispositivos de protección contra caídas mediante planos (p. ej. esquema de vista del tejado).
- En las superficies de tejado inclinadas, se deberán instalar barreras de retención para la nieve adecuadas para evitar que se produzcan desprendimientos de nieve (hielo, nieve), para que los dispositivos de protección contra caídas no resulten dañados.

Montaje seguro

- El acero inoxidable no debe entrar en contacto con polvo de lijado o con herramientas de acero. Esto puede provocar la formación de corrosión.
- La fijación correcta de los dispositivos de protección contra caídas en el edificio debe documentarse mediante el acta de correcta instalación y fotografías de la situación de montaje correspondiente.
- El montador debe asegurarse de que la capa de fondo es adecuada para la fijación de los dispositivos de protección contra caídas. En caso de duda, deberá consultarse a un especialista en cálculos estáticos.
- Las distancias de los dispositivos de protección contra caídas con respecto al borde de caída debe establecerse de acuerdo con las prescripciones y las normas aplicables localmente y en función de la geometría del tejado.

HU Biztonsági előírások

Általános információk

- A rendszert csak az erre megfelelően kiképzett, a leesésvédelmi rendszereket ismerő szakember telepítheti.
- A leesésvédelmi rendszer beépítőjének ismernie kell a helyi, a biztonságtechnikai és a munkavédelmi előírásokat és azokat maradéktalanul be kell tartania.
- A leesésvédelmi rendszer megközelítési pontjánál a rendszer tervrajza (vagy egy vázlatos rajz a tető felülnézetéről) elérhető kell, hogy legyen.
- Ferde tető esetén a hófogó rendszert úgy kell kialakítani, hogy a hó vagy jég a távozás során a rendszert vagy annak elemeit ne károsítsa.

Biztonságos telepítés

- Rozsdamentes acél alkotóelemek közzőrűporral vagy fém szerszámokkal nem érintkezhetnek, mert az korrózióhoz vezethet.
- A leesésvédelmi rendszer szakszerű rögzítését a helyszínen a nyomaték ellenőrzésével és a beépítési körülményeiről készült fotókkal dokumentálni kell.
- A beépítőnek biztosítania kell azt, hogy a kikötési rendszer rögzítéséhez az aljzat állapota megfelelő. Kétely esetén az aljzatot statikussal ellenőriztetni kell.
- A leesésvédelmi rendszer távolsága a tető szélétől a helyi előírásoknak megfelelően és a tető geometriájának függvényében lett kiválasztva.

EN Mounting surface

The prerequisite for proper and professional installation is a statically sound construction and the use of the original fastening components listed in the Technical Manual.



Danger of death during installation!

- The fall protection system may only be installed on a statically load-bearing substructure!
- Do not install in streed, blinding concrete, sloping concrete, etc.!
- The roof structure must be statically inspected!
- The technical specifications of the Technical Manual must be completely observed!
- In case of the use of fastening elements, anchors other than those described in the Technical Manual, the responsibility lies with the installer.

DE Montageuntergrund

Grundvoraussetzung für eine fachgerechte Montage ist eine statisch tragfähige Konstruktion und die Verwendung der empfohlenen, in der Montageanleitung aufgeführten Befestigungsmittel.



Lebensgefahr bei der Montage!

- Die Absturzsicherungen dürfen nur auf statisch tragfähigen Konstruktionen (Beton, Holz, Stahlblech) installiert werden!
- Die Montage auf Überzugs- und Ausgleichsbeton ist verboten!
- Die Dachkonstruktion zur Aufnahme der eingeleiteten Kräfte ist bauseits (z.B. durch Statiker) zu prüfen.
- Die technischen Bestimmungen in der Montageanleitung sind einzuhalten.
- Die Verwendung von anderen Befestigungsmitteln als in der Montageanleitung angegeben liegt in der Verantwortung des Monteurs.

FR Support de montage

La condition élémentaire à un montage correct / professionnel est un **construction**, ainsi que l'utilisation des moyens de fixation d'origine détaillés dans cette notice.



Danger de mort en cas de montage sur un support inadapté!

- Le système doit être installé sur un support porteur en béton de construction!
- Il est interdit d'installer le système dans la chape, le béton de ragréage, le béton du radier, etc...
- Il faut vérifier le support de montage par un ingénieur B.T.P.
- Il faut respecter les dispositions de Guide d'installation pendant montage!
- Utilisation des éléments de fixation d'un autre fabricant est la responsabilité du monteur.

IT Sottotondo di montaggio

Prerequisito per il montaggio è sottotondo staticamente stabile e l'utilizzo di articoli di fissaggio indicati nelle istruzioni di montaggio.



Pericolo di vita durante il montaggio!

- I sistemi anticaduta possono essere installati soltanto sottostrutture staticamente portanti!
- Il montaggio su cemento di copertura o di compensazione è proibito!
- Il tetto deve essere controllato per le forze trasmesse da un ingegnere strutturale.
- Bisogna seguire le specifiche tecniche delle istruzioni di montaggio in ogni sua parte.
- Nel caso di utilizzo di elementi di fissaggio diversi da quelli indicati nelle istruzioni di montaggio, la responsabilità sarà del Montatore.

ES Superficie de montaje

El requisito básico para un montaje adecuado es una construcción estáticamente estable y la utilización de los medios de fijación recomendados que se indican en las instrucciones de montaje.



Peligro de muerte durante el montaje!

- Los dispositivos de protección contra caídas solo deben instalarse sobre una estructura estáticamente estable.
- El montaje sobre hormigón de revestimiento o de compensación está prohibido.
- La construcción del tejado debe comprobarse en obra en cuanto a la capacidad de absorción de las fuerzas aplicadas (p. ej. por un especialista en cálculos estáticos).
- Las disposiciones técnicas especificadas en las instrucciones de montaje deben respetarse.
- La utilización de medios de fijación distintos a los indicados en las instrucciones de montaje será responsabilidad exclusiva del montador.

HU Az alaptestre vonatkozó előírások



A szakszerű telepítés előfeltétele egy statikai szempontból teherviselésre alkalmas szerkezet, és a megfelelő, a Beépítési útmutatóban megjelölt rögzítőelemek alkalmazása.

Életveszély a beépítés alatt!

- A leesésvédelmi rendszert csak statikai szempontból teherhordó szerkezetre szabad telepíteni!
- Nem szabad utánöntött aljzatbetonra, kitöltőbetonra, esztrichbetonra telepíteni!
- A tetőszerkezetet az arra ható erők szempontjából statikai szempontból ellenőrizni kell!
- A Beépítési útmutató műszaki előírásait maradéktalanul be kell tartani!
- A Beépítési útmutatóban leírtakhoz képest eltérő rögzítőelem, dübel használata a beépítő felelősségét terheli.

Installation / Montage / Installation / Montaggio / Montaje / Telepítés

Installation tools / Nötige Hilfsmittel / Outils nécessaires / Attrezzi per il montaggio / Herramientas necesarias / Szükséges szerszámok

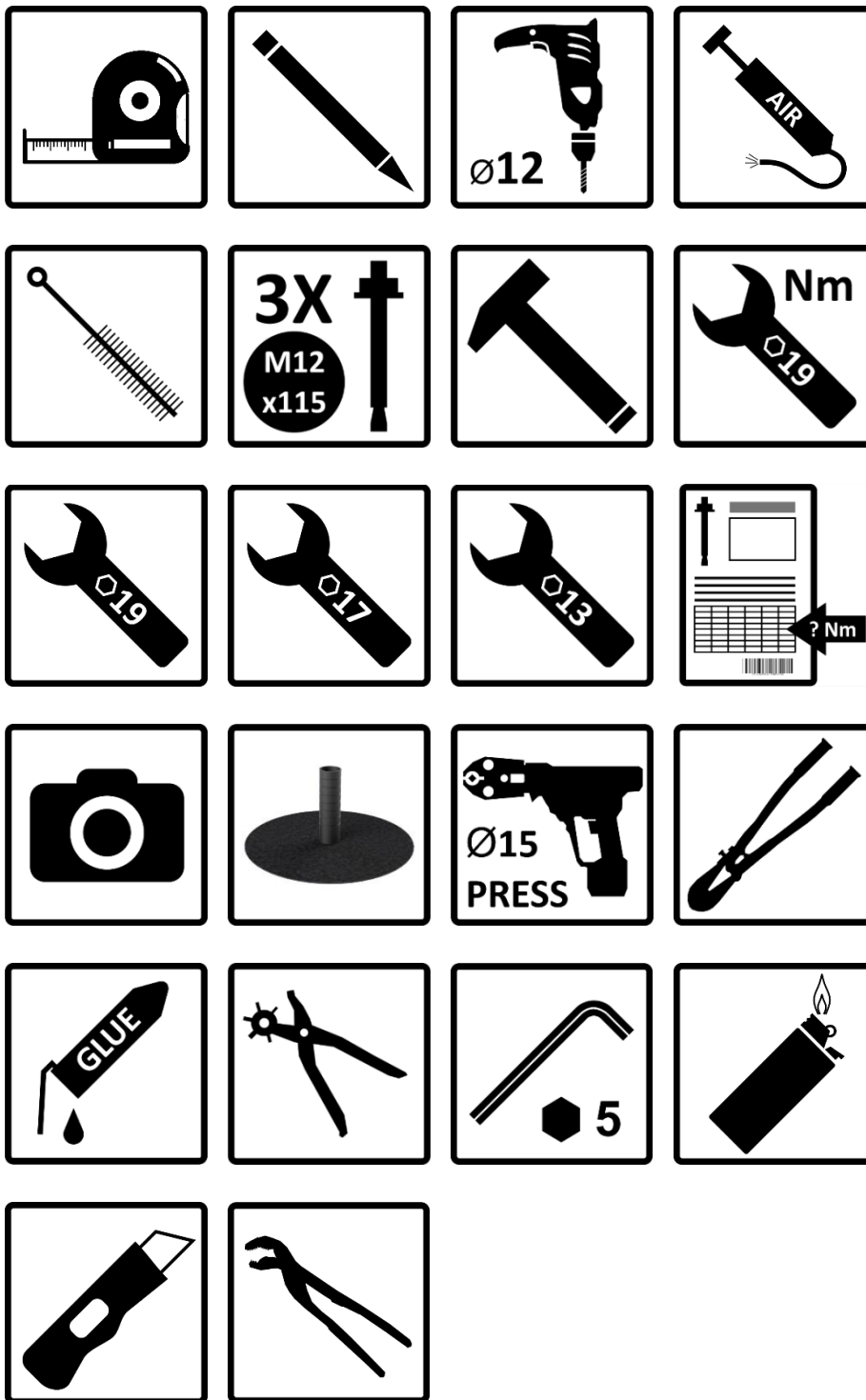

Lubricant / Schmiermittel / Lubrifiant / Lubrificante / Lubricante / Kenőanyag



Cable sag / Seildurchhang / Flèche de câble / Freccia del cavo / Flecha del cable / Sodronybelógás :

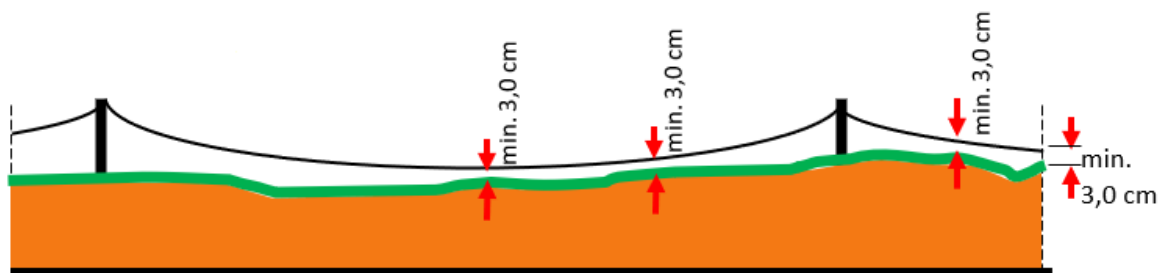

EN: The cable sag may not reach higher than 3.0 cm above the roof surface. The lateral mobility of the rope shall be ensured at all times, and shall be checked before each use!
E.g.: green roof structure, but applicable to all roof structures.

DE: Der Seildurchhang darf maximal bis auf 3,0 cm oberhalb der Dach-Oberfläche reichen. In jedem Fall muß die seitliche Beweglichkeit des Seiles sichergestellt sein und muß vor jeder Benutzung geprüft werden!
z.B. Dachaufbau Gründach, gilt aber auch für jeden anderen Dachaufbau

FR: La flèche de câble ne peut pas dépasser 3,0 cm au-dessus de la surface du toit. La mobilité latérale de la corde doit être assurée toujours et doit être vérifiée avant chaque utilisation!
Par exemple: structure de toiture végétale, mais applicable à toutes les structures de toiture

IT : La freccia del cavo non deve superare i 3,0 cm sopra la superficie del tetto. In ogni caso, la mobilità laterale della fune deve essere garantita e deve essere controllata prima di ogni utilizzo!
ad es. struttura tetto verde, ma si applica anche a qualsiasi altra struttura del

ES : La flecha del cable debe llegar hasta un máximo de 3,0 cm por encima de la superficie del tejado. En cada caso deberá asegurarse la movilidad lateral del cable y deberá comprobarse antes de cada uso.
P. ej., estructura del tejado de tejado verde, pero también es válido para todas las otras estructuras.

HU : A sodrony belógása legfeljebb 3 cm lehet a tetőfelület felett. Minden esetben biztosítani kell a sodrony oldal irányú mozgását, és azt minden használat előtt ellenőrizni kell.
pl.: zöldtető, de bármilyen más tetőre is érvényes.

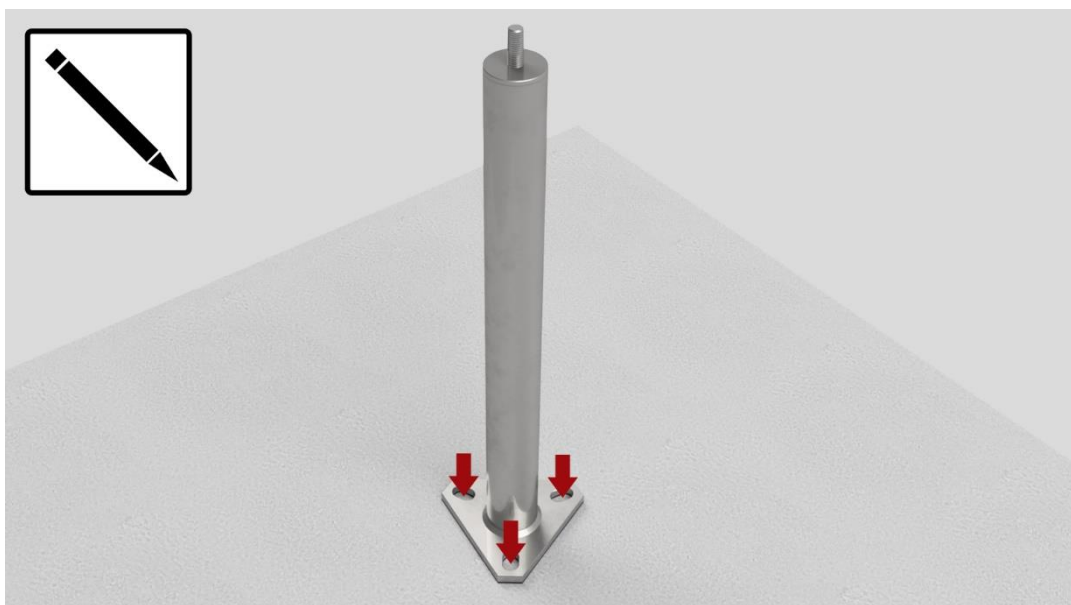
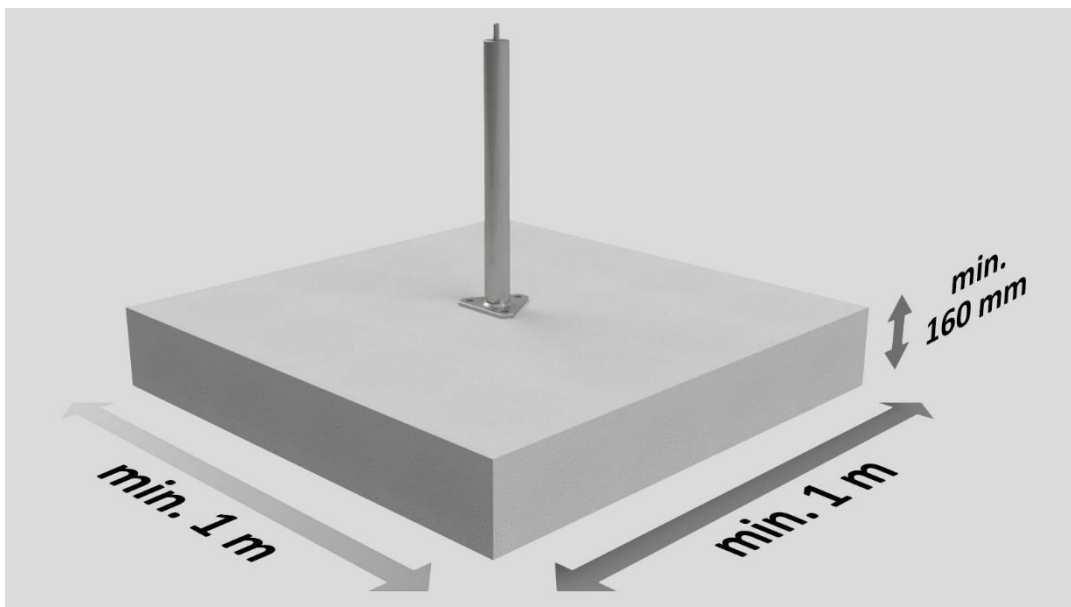
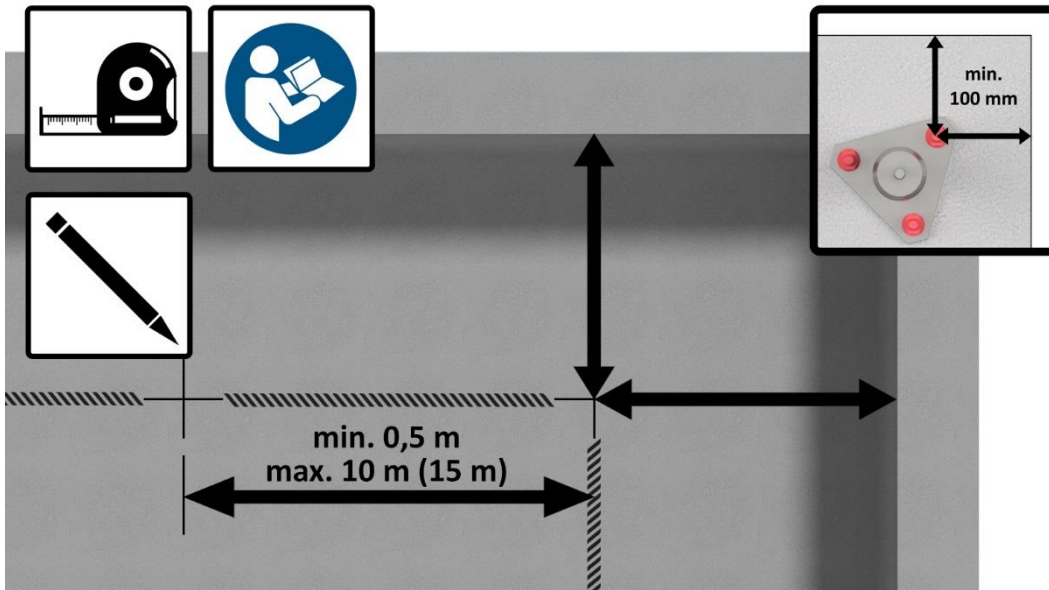

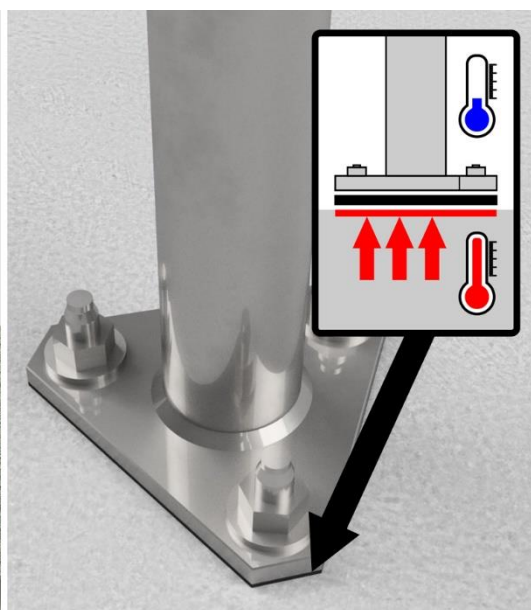
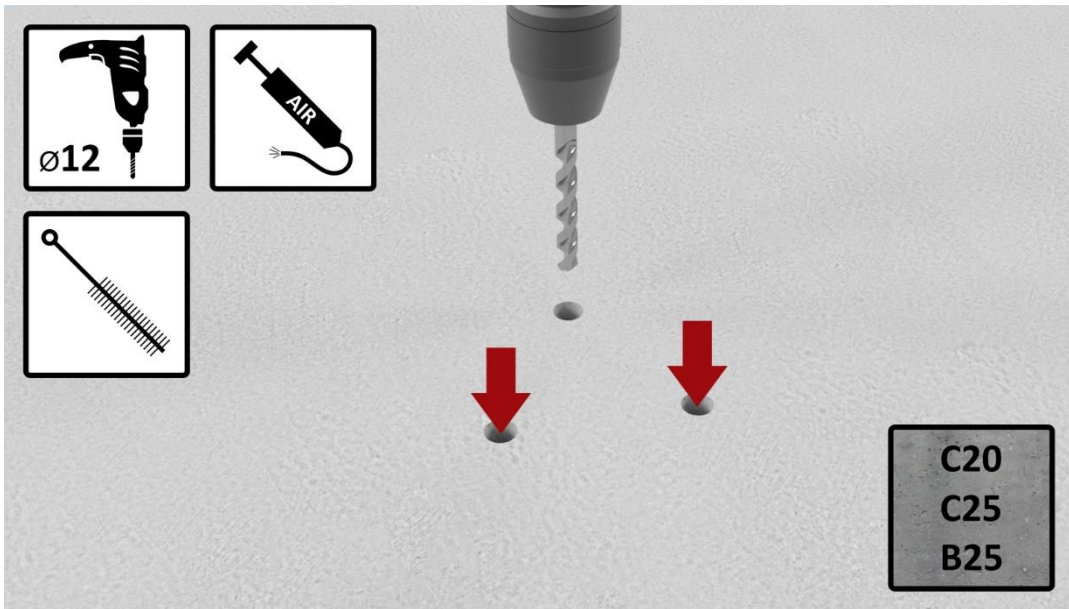

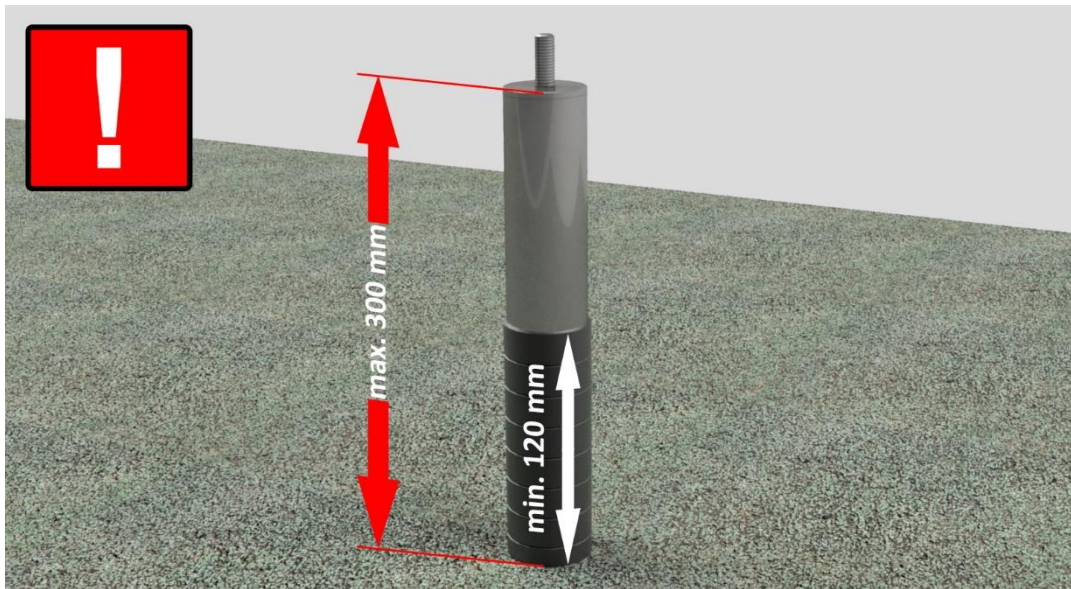

 See technical manual / Siehe Gebrauchsanleitung / Voir le manuel technique / Vedi manuale tecnico / Ver Manual Técnico / Lásd Műszaki kézikönyv

SINGLE SYSTEM

Singlesystem installation / Montageablauf Singlesystem / Installation d'un système ouvert /
Montaggio sistema aperto / Montaje del sistema abierto/ Szoliter rendszer telepítése



SINGLE SYSTEM | A

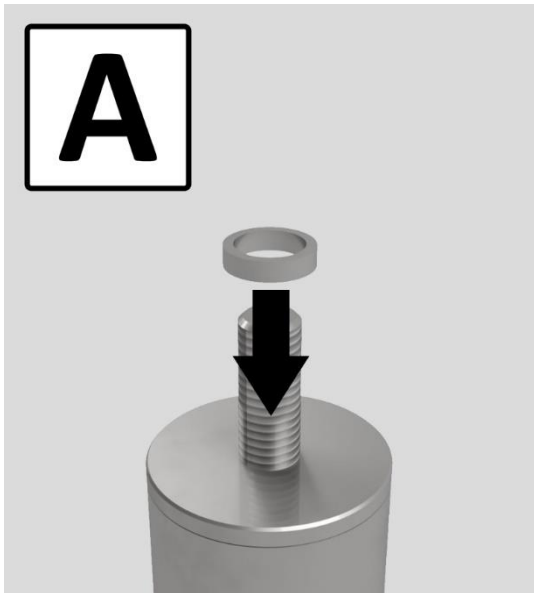
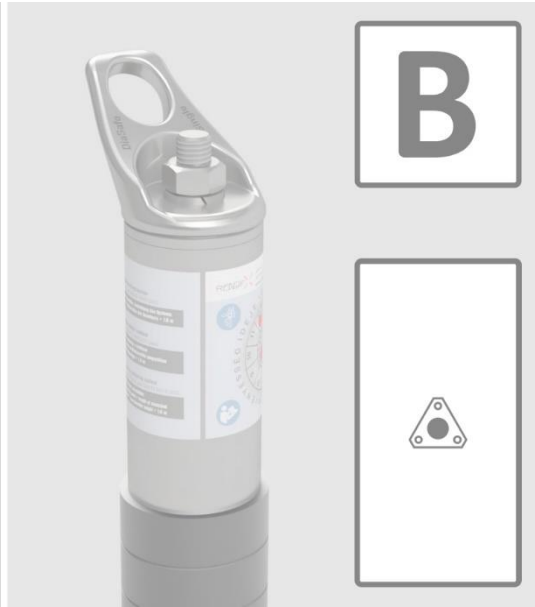
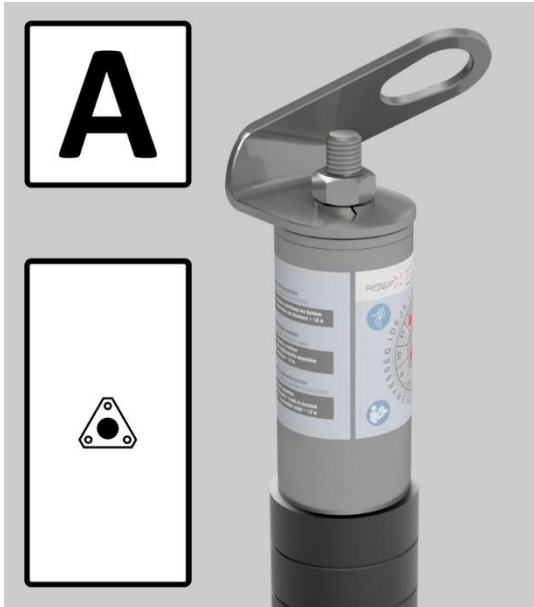



SINGLE SYSTEM | A

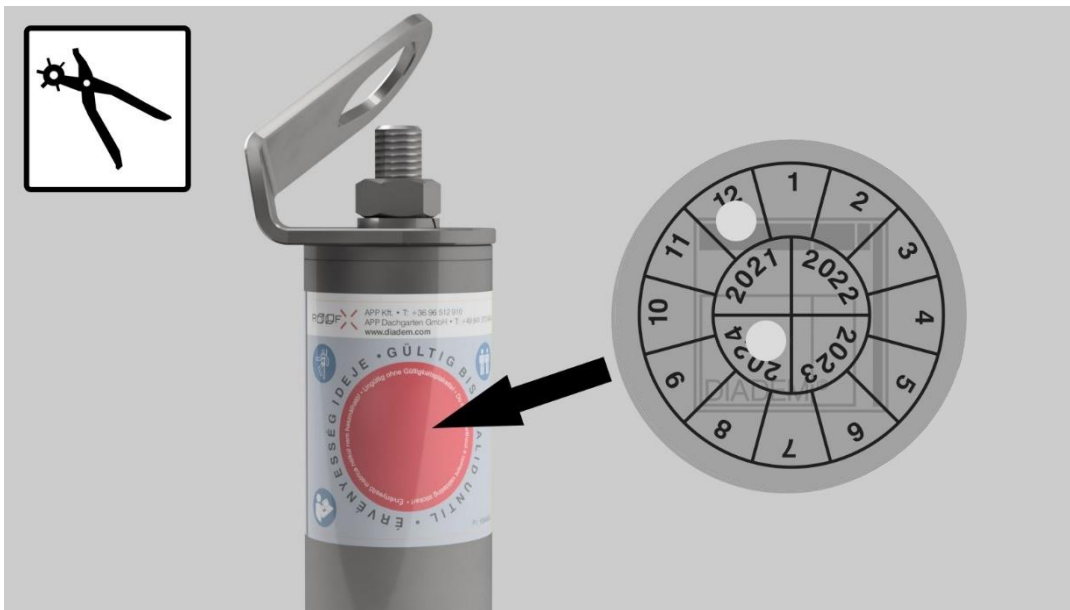

Use according to Technical Manual / Benützung gemäss Gebrauchsanleitung / À utiliser conformément au mode d'emploi / Utilizzo secondo il Manuale Tecnico / Uso de acuerdo con el manual de instrucciones / Műszaki kézikönyv szerinti használat



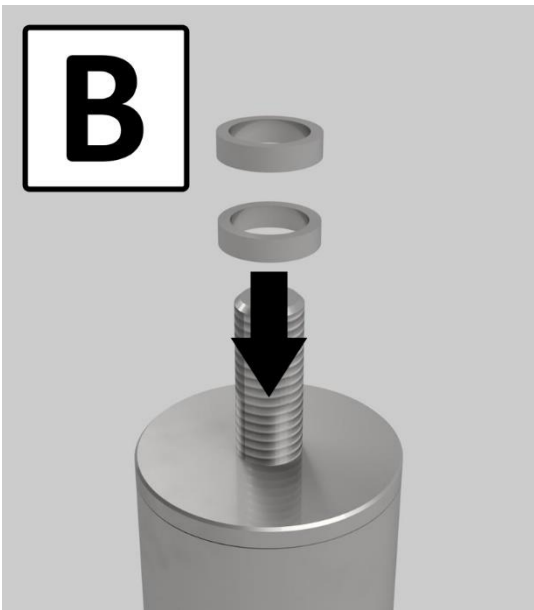
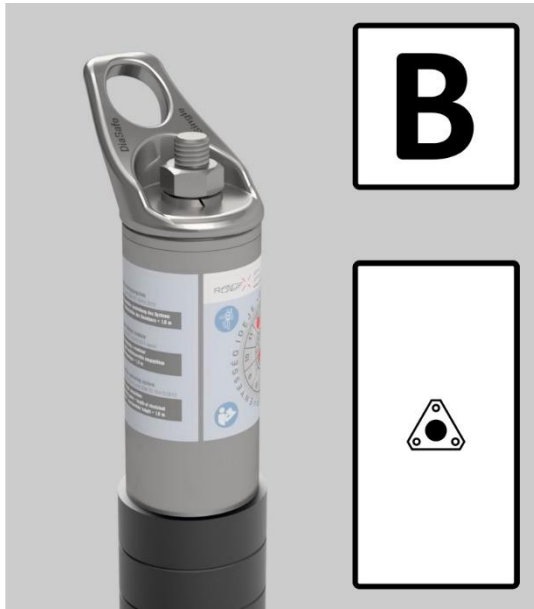

SINGLE SYSTEM | B

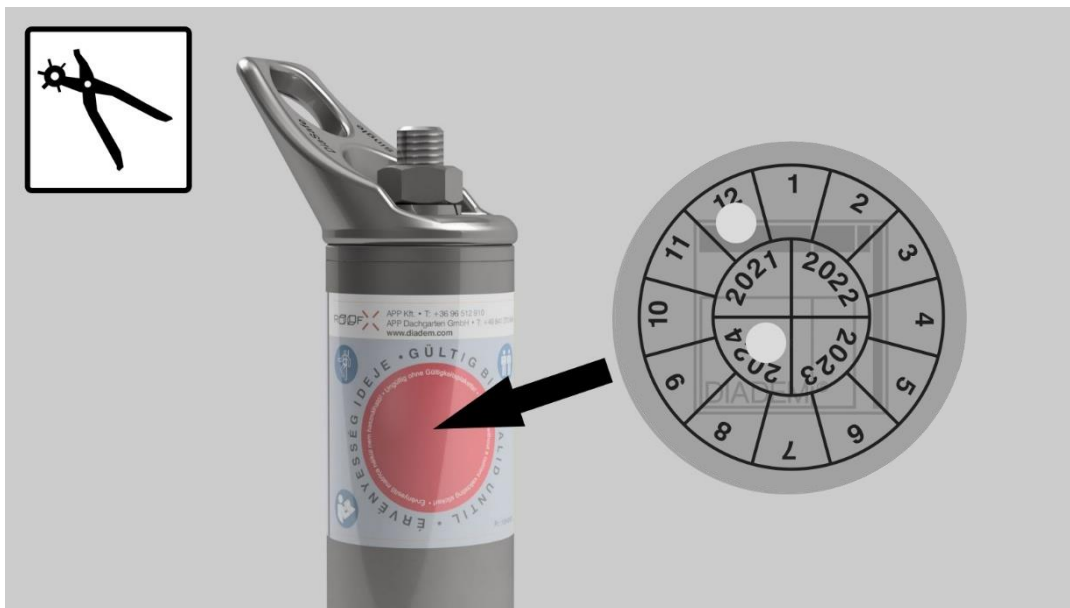

Use according to Technical Manual / Benützung gemäss Gebrauchsanleitung / À utiliser conformément au mode d'emploi / Utilizzo secondo il Manuale Tecnico / Uso de acuerdo con el manual de instrucciones / Műszaki kézikönyv szerinti használat



GLIDE SYSTEM



GLIDE SYSTEM | C

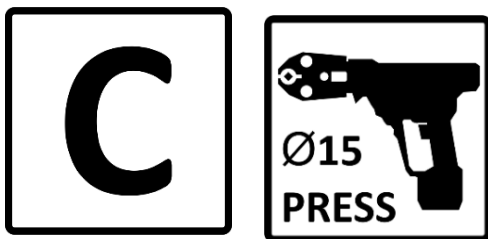
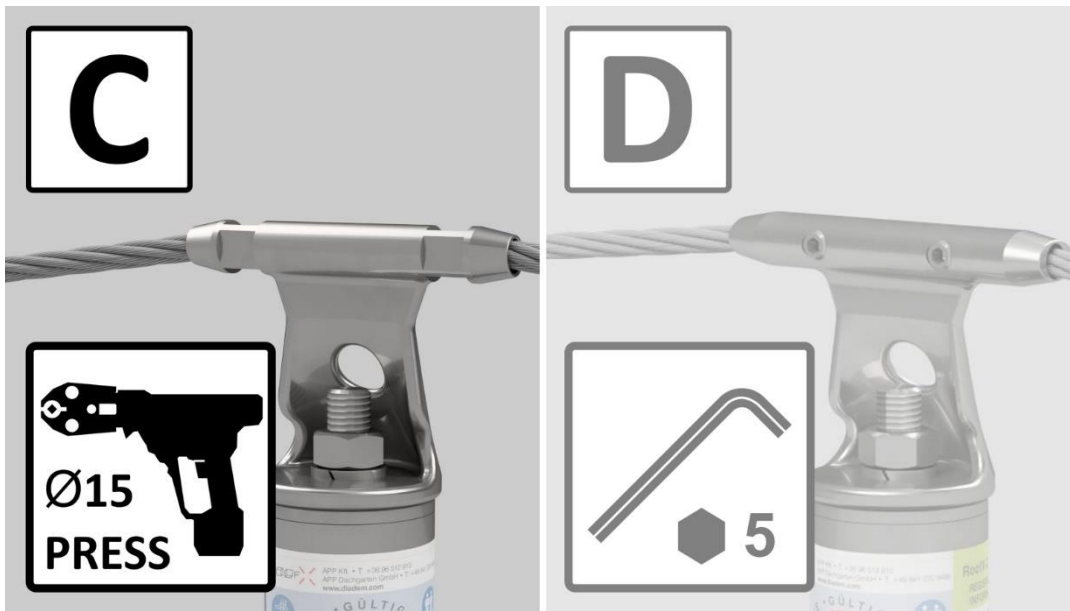

Open linesystem installation (with start- and end posts) / Montageablauf offenes Seilsystem (mit Anfangs- und Endstütze) / Installation d'un système ouvert (avec Start- et Fin potelet) / Montaggio sistema aperto (con supporto iniziale e terminale) / Proceso de montaje del sistema de cable abierto (con soporte de apoyo inicial y final) / Nyílt rendszer telepítése (kezdő- és végszloppal)

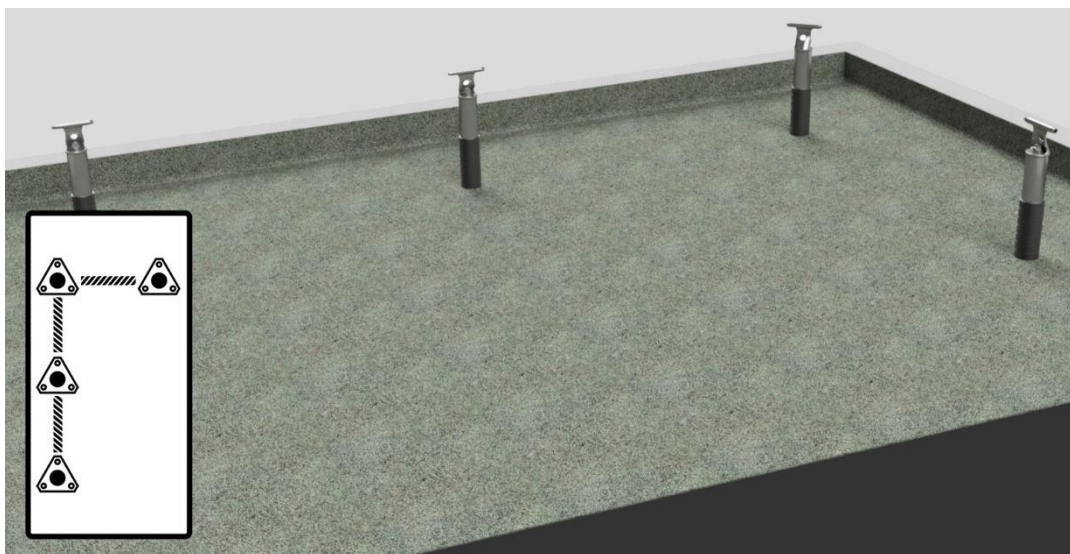



GLIDE SYSTEM | C

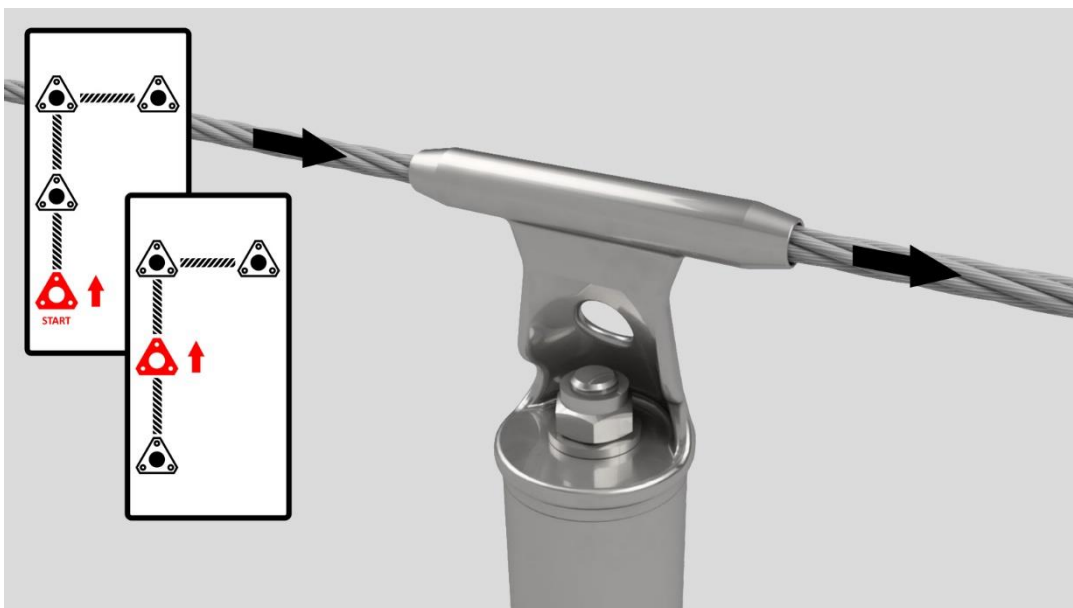
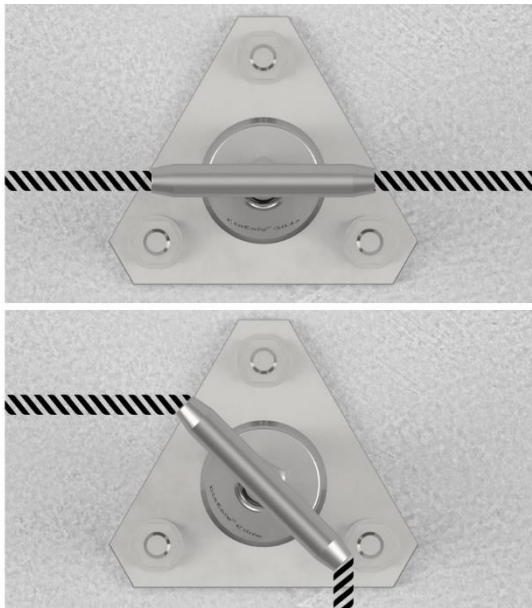

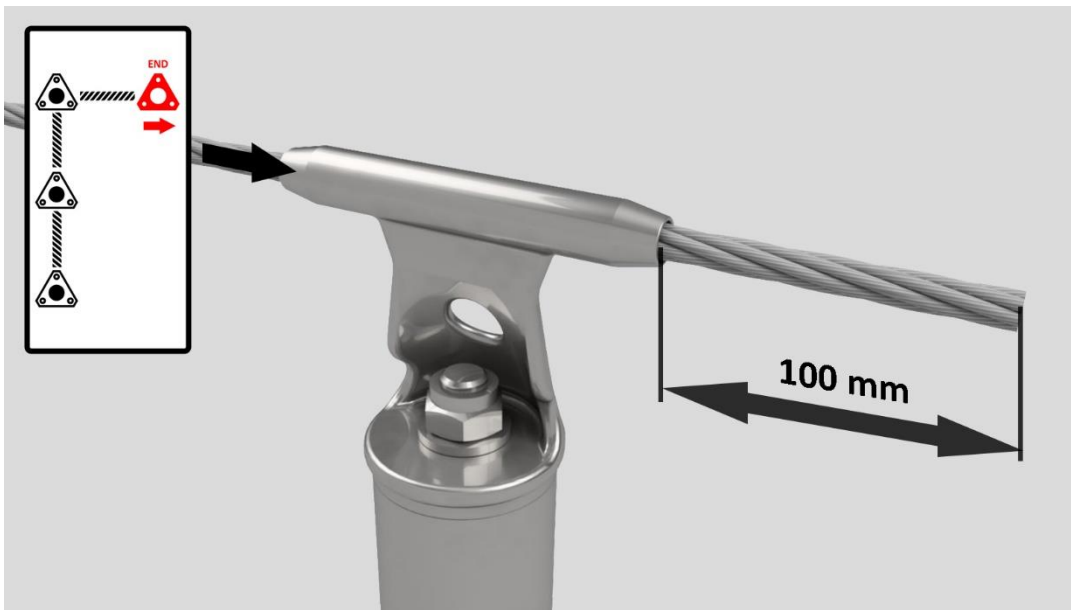

GLIDE SYSTEM | C



GLIDE SYSTEM | C

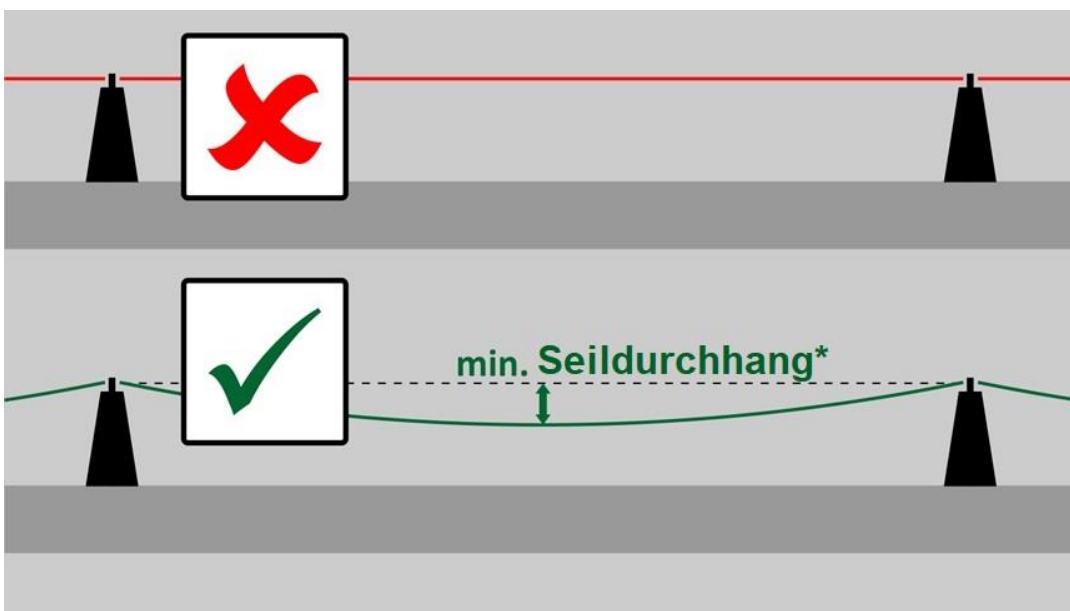
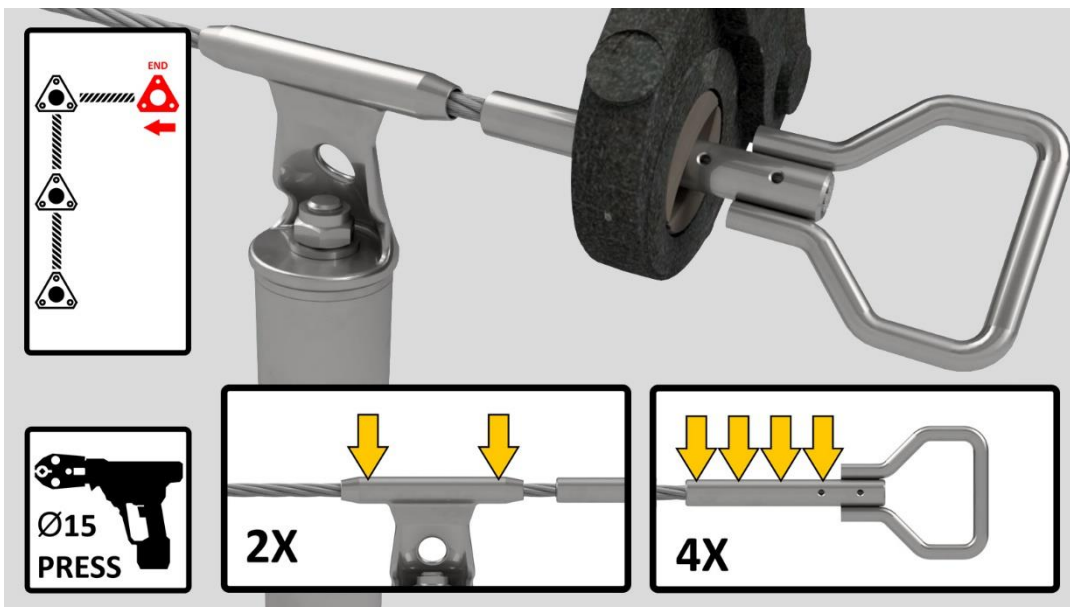
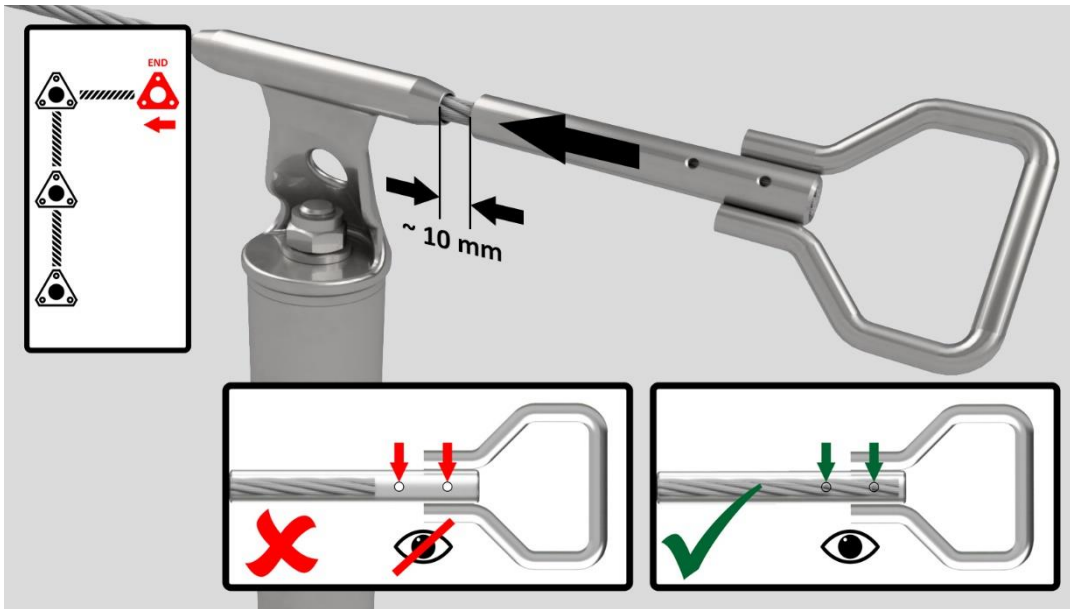

* see page 5 / Siehe Seite 5 / voir page 5 / vedi pagina 5 / Véase la página 5 / lásd 5. oldal

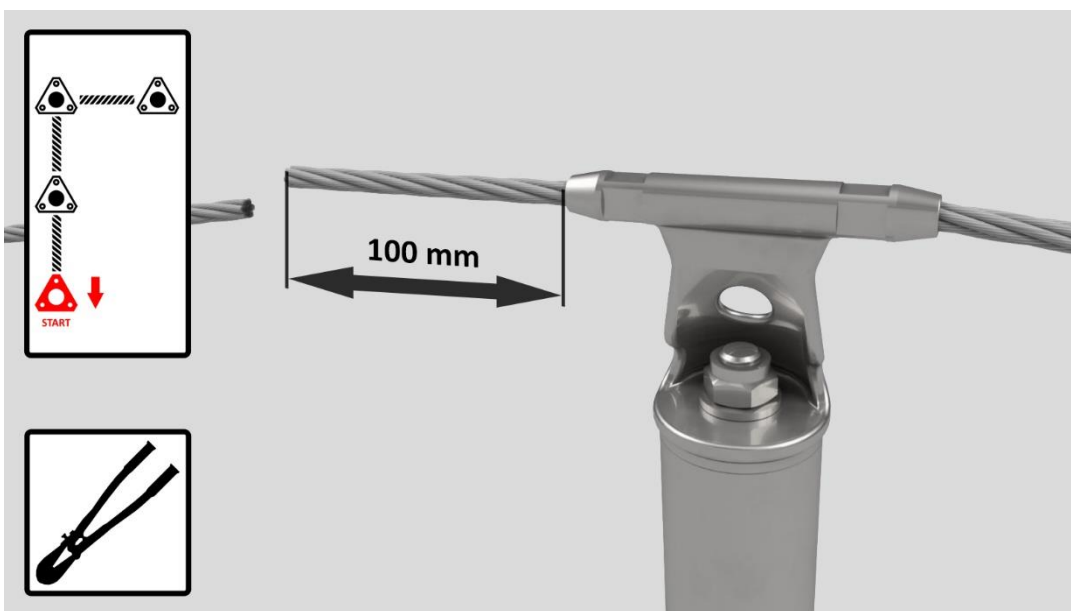
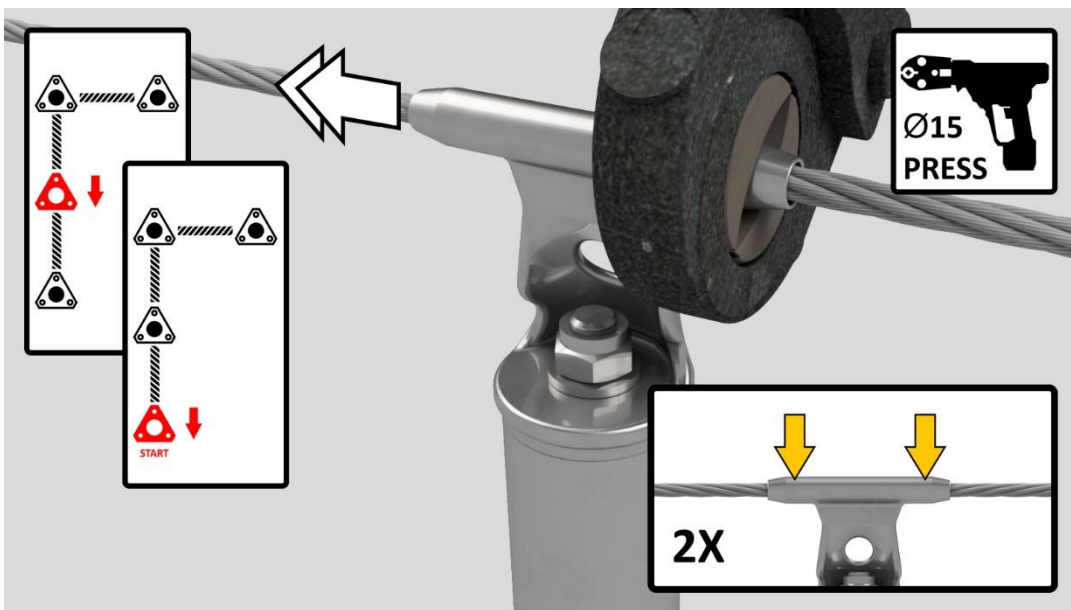
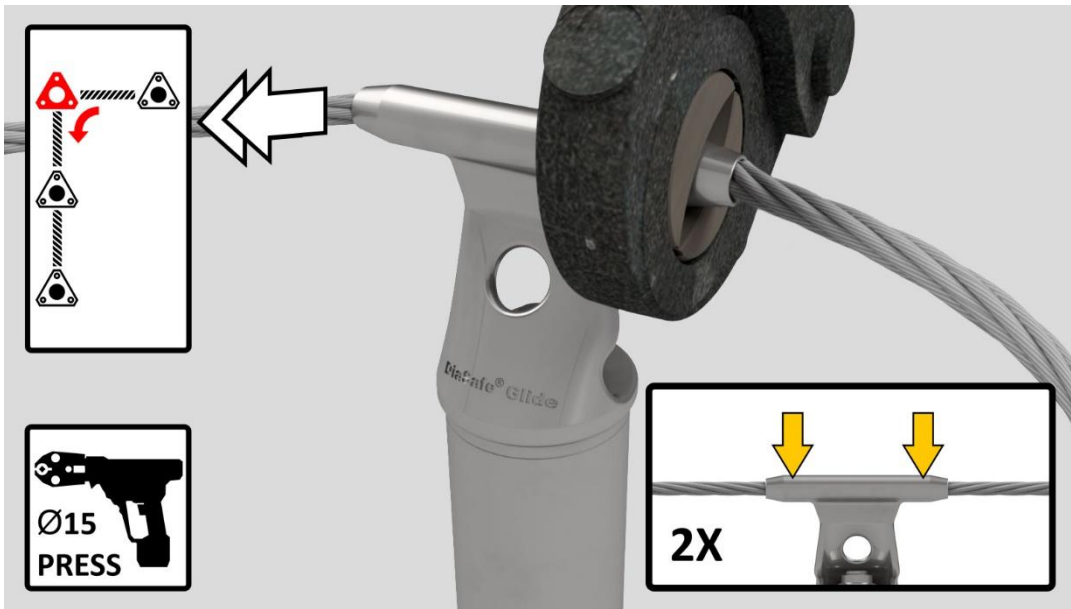

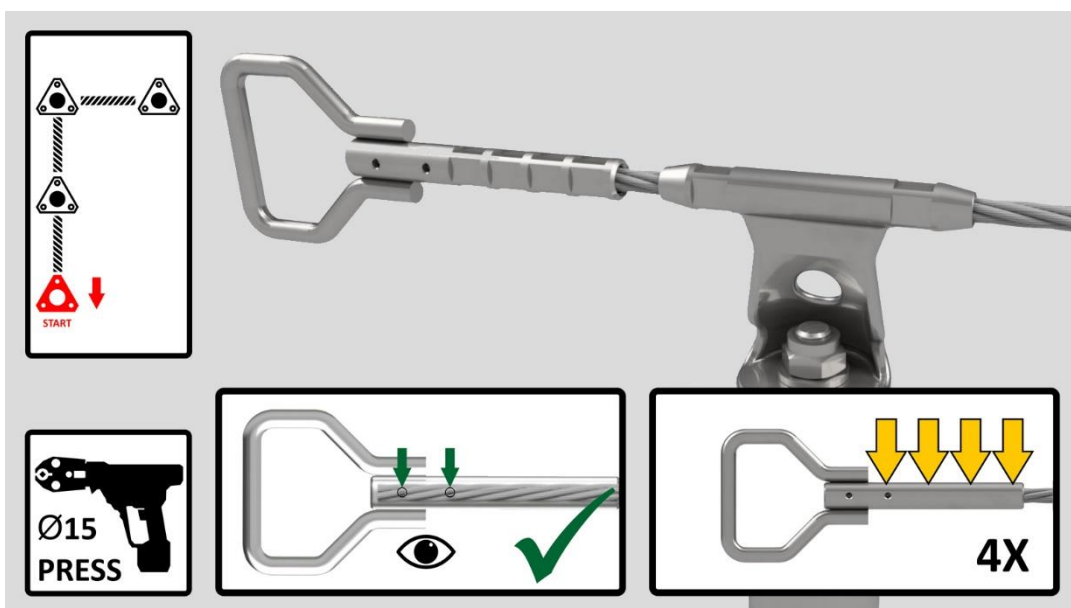
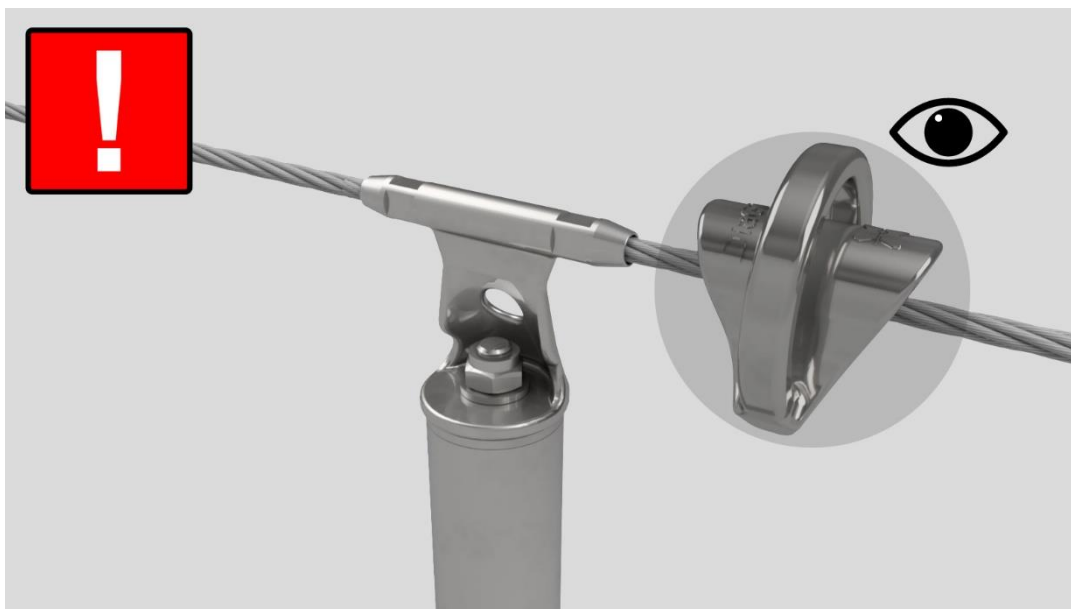

Closed linesystem installation (without start- and end posts) / Montageablauf umlaufendes Seilsystem (ohne Anfangs- und Endstütze) / Installation d'un système fermé (sans Start- et Fin potelet) / Installazione di un sistema chiuso (senza colonna iniziale e terminale / Proceso de montaje del sistema de cable cerrado (sin soporte de apoyo inicial y final) / Sodronyos zárt rendszer telepítése (kezdő- és végoszlop nélkül)



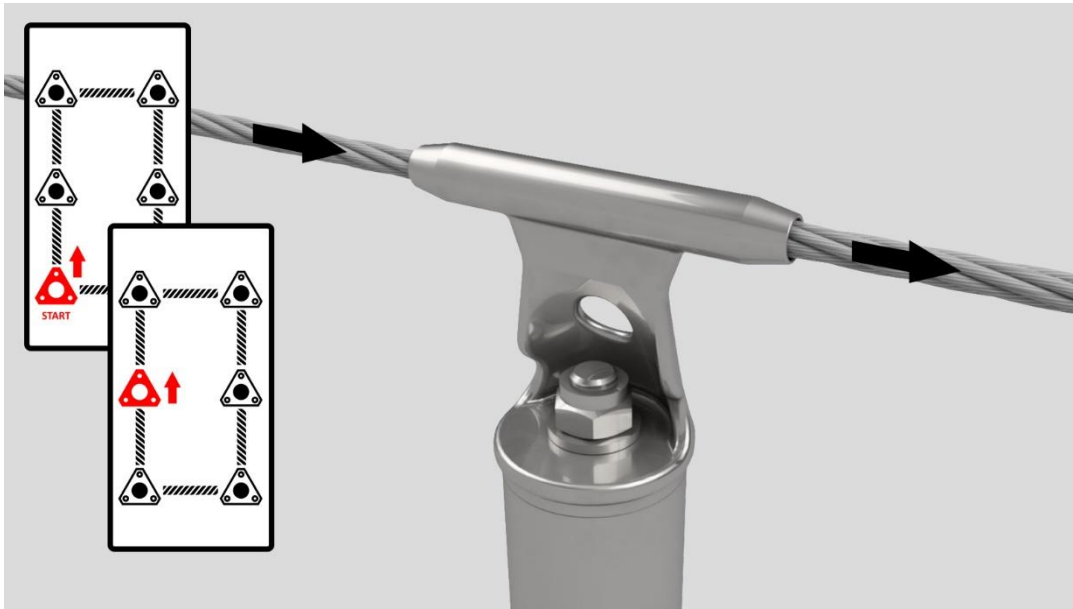

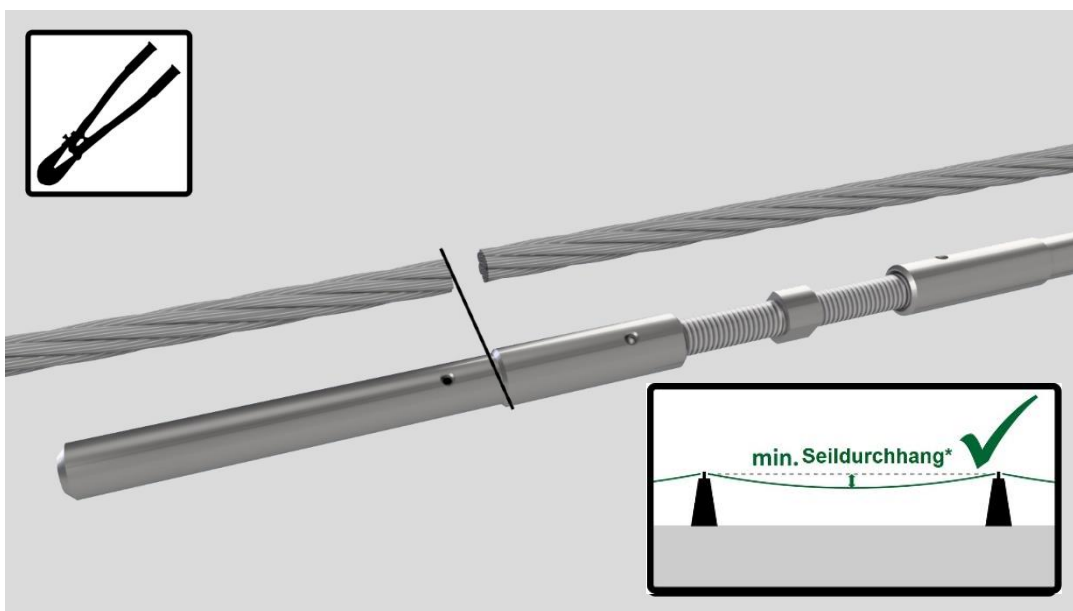
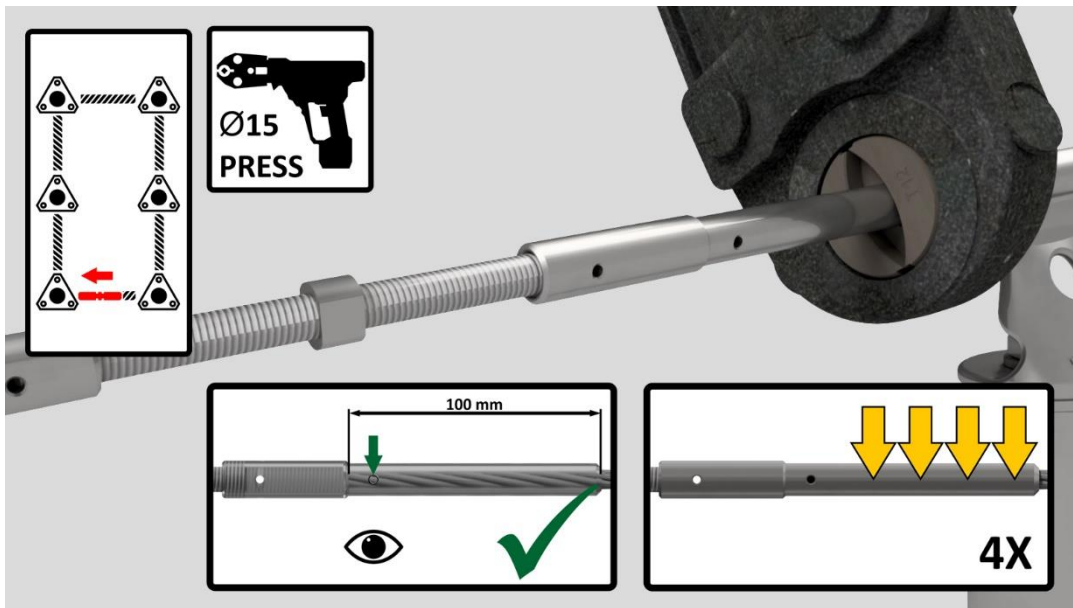
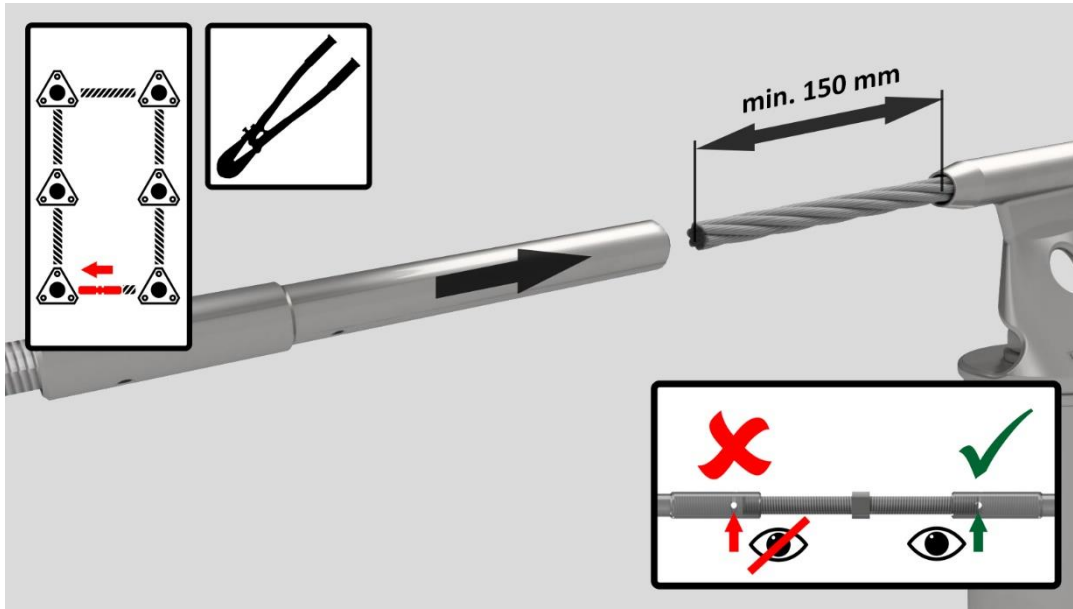

* see page 5 / Siehe Seite 5 / voir page 5 / vedi pagina 5 / Véase la página 5 / lásd 5. oldal

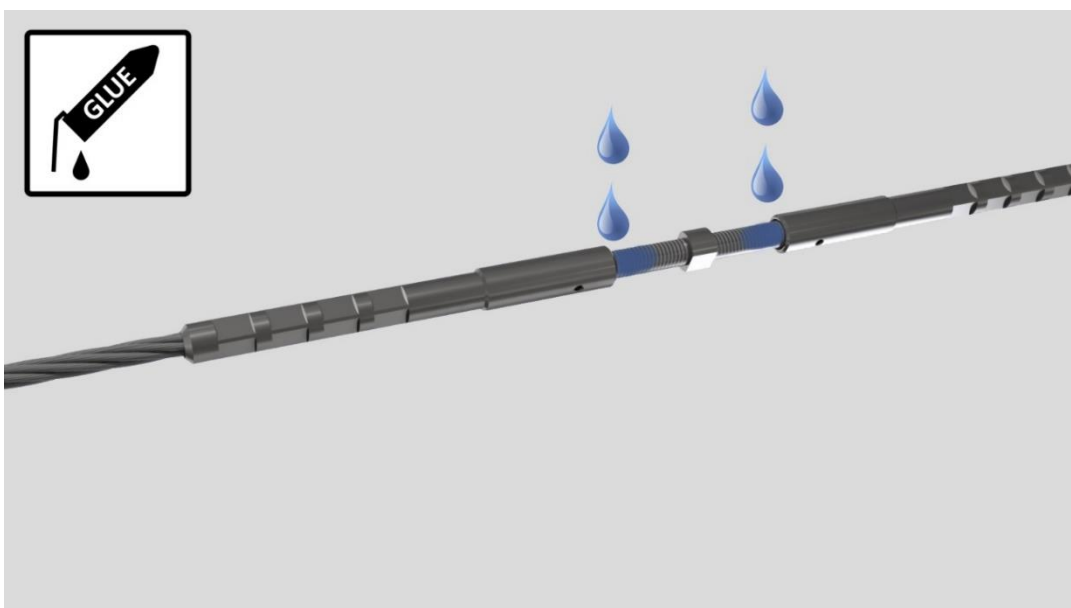
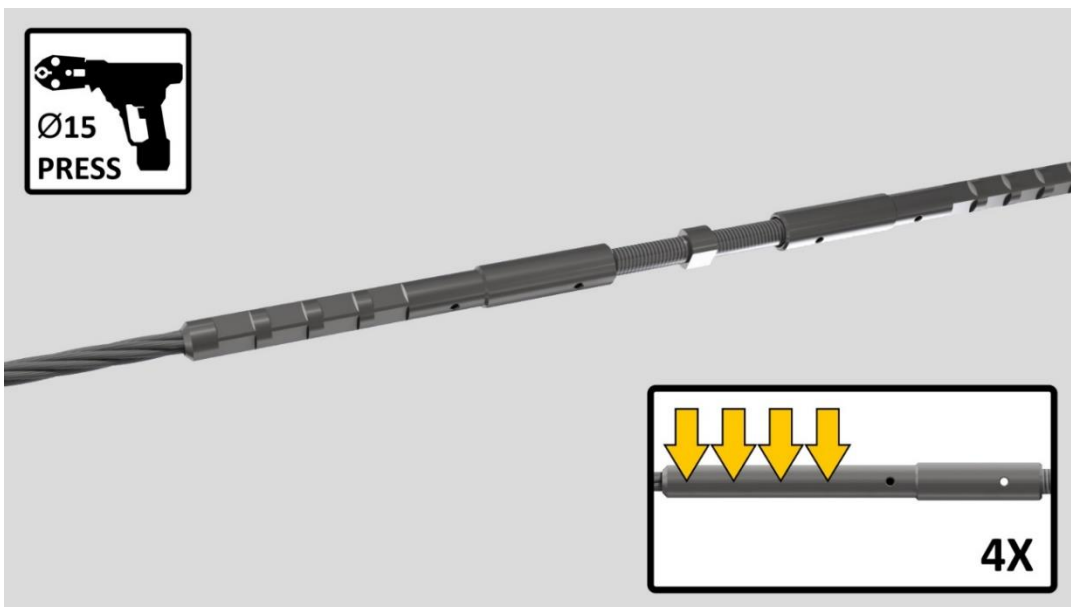

GLIDE SYSTEM | C



GLIDE SYSTEM | C

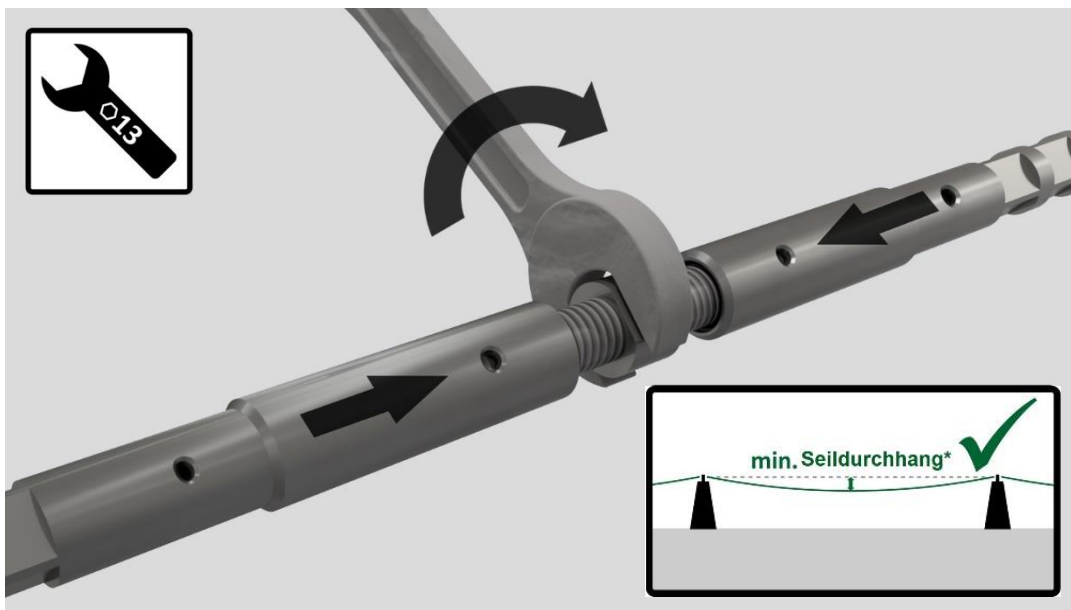
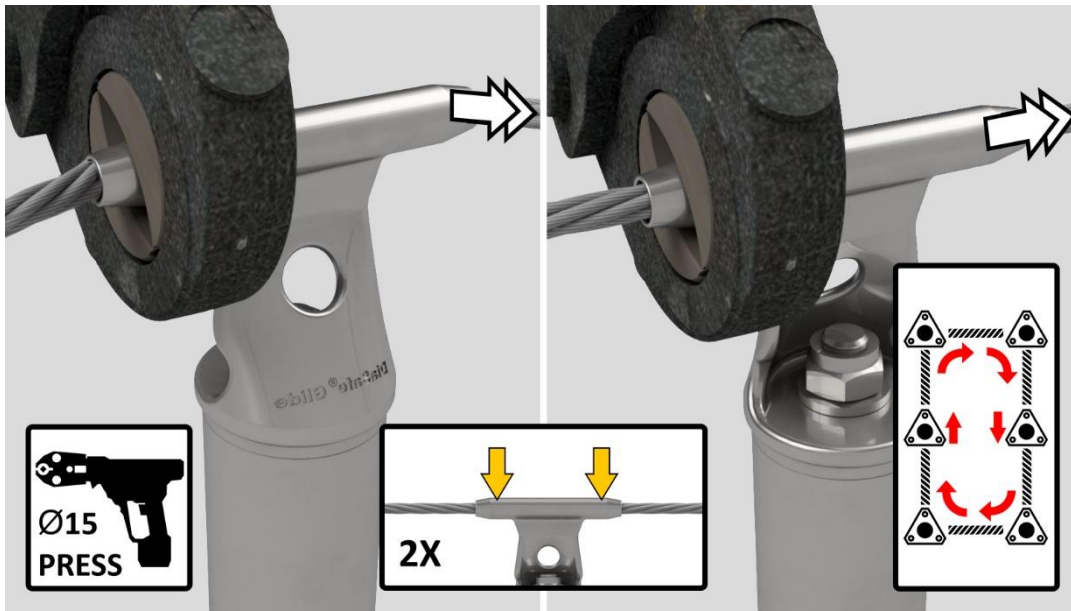

* see page 5 / Siehe Seite 5 / voir page 5 / vedi pagina 5 / Véase la página 5 / lásd 5. oldal

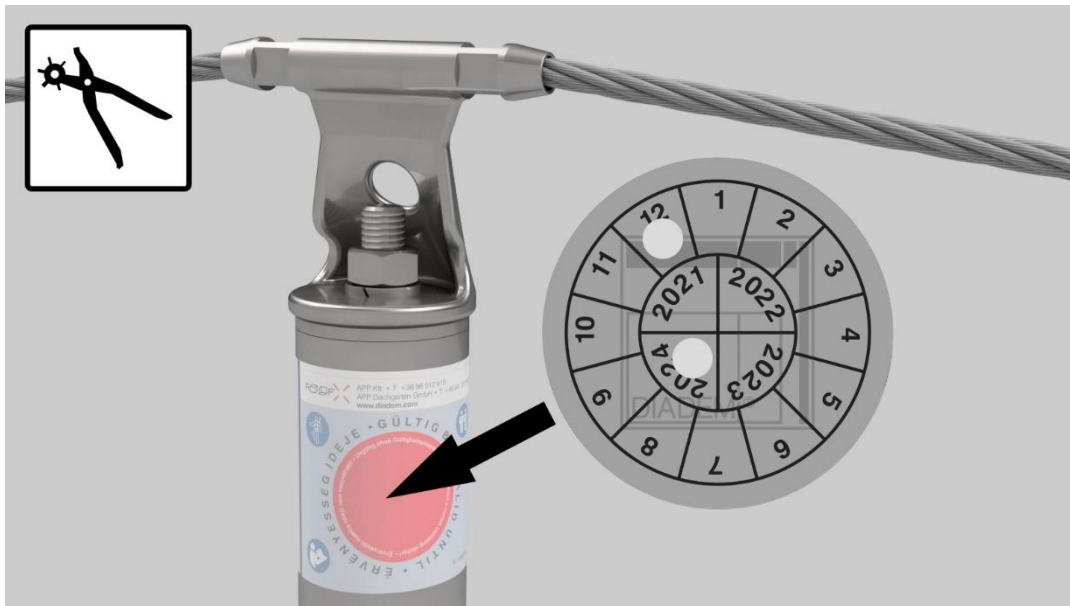

GLIDE SYSTEM | C

Use according to Technical Manual / Benützung gemäss Gebrauchsanleitung / À utiliser conformément au mode d'emploi / Utilizzo secondo il Manuale Tecnico / Uso de acuerdo con el manual de instrucciones / Műszaki kézikönyv szerinti használat





OPTIONAL 1

Start- and end posts / Anfangs- und Endstütze / Start- et Fin potelet / Con colonna iniziale e terminale / Con columna de inicio y fin / Kezdő- és végszlop

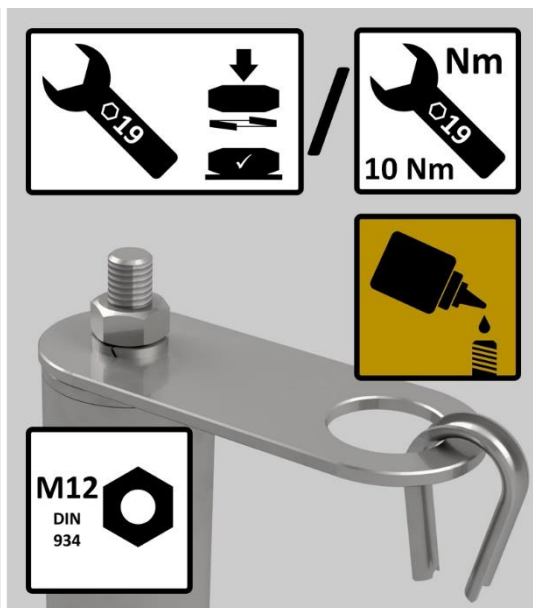
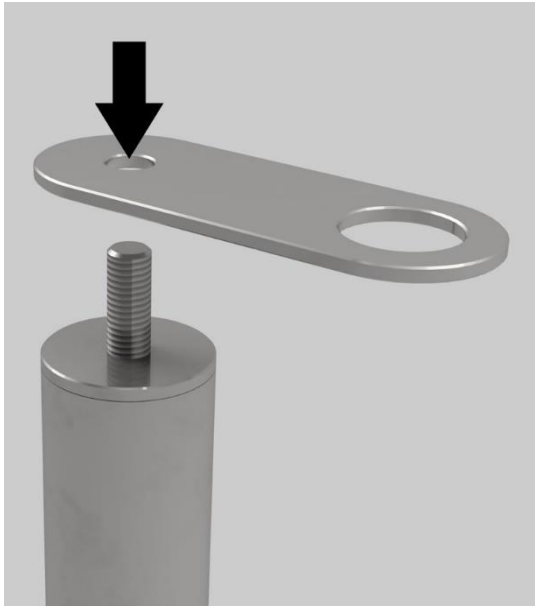
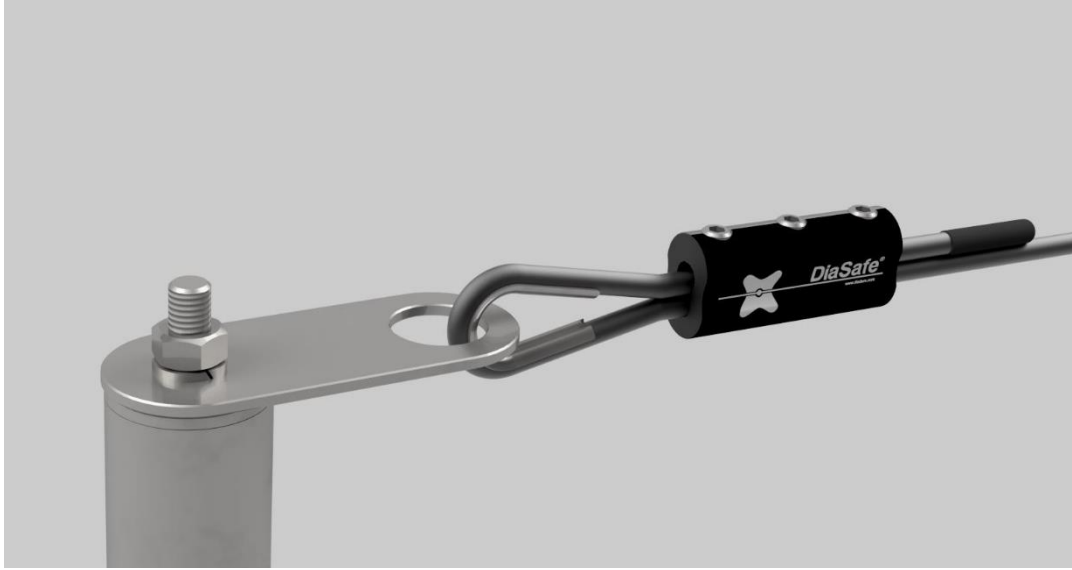

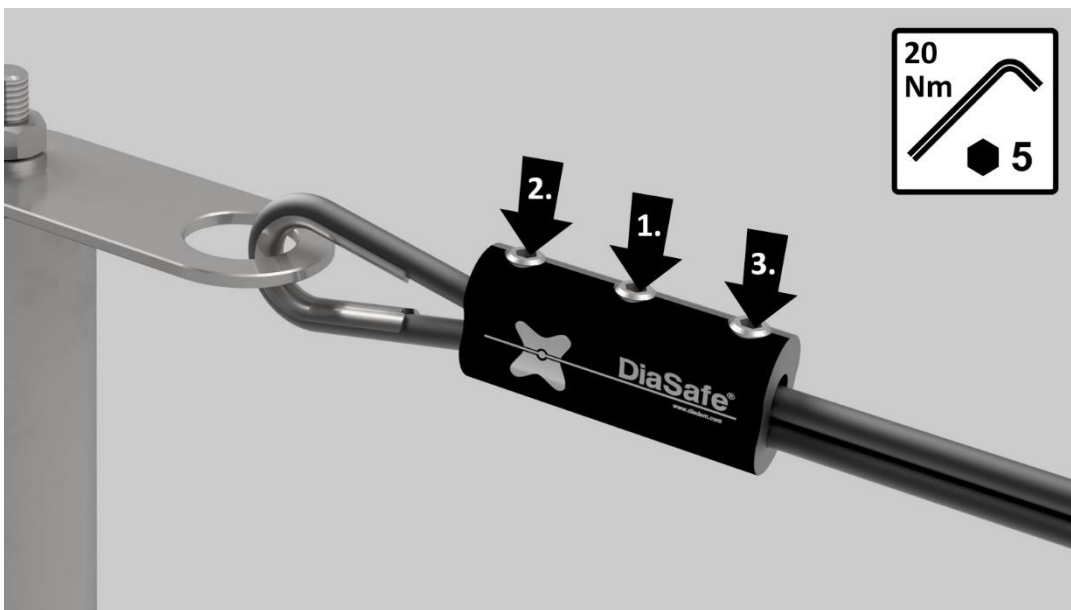
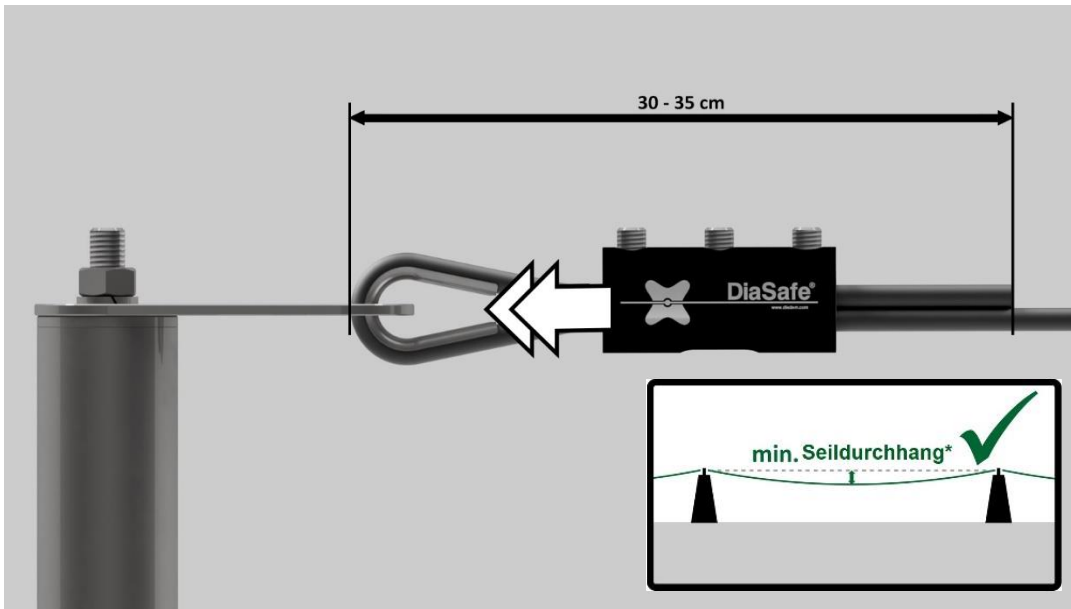

* see page 5 / Siehe Seite 5 / voir page 5 / vedi pagina 5 / Véase la página 5 / lásd 5. oldal



OPTIONAL 2

Start- and end posts / Anfangs- und Endstütze / Start- et Fin potelet / Con colonna iniziale e terminale / Con columna de inicio y fin / Kezdő- és végszlop

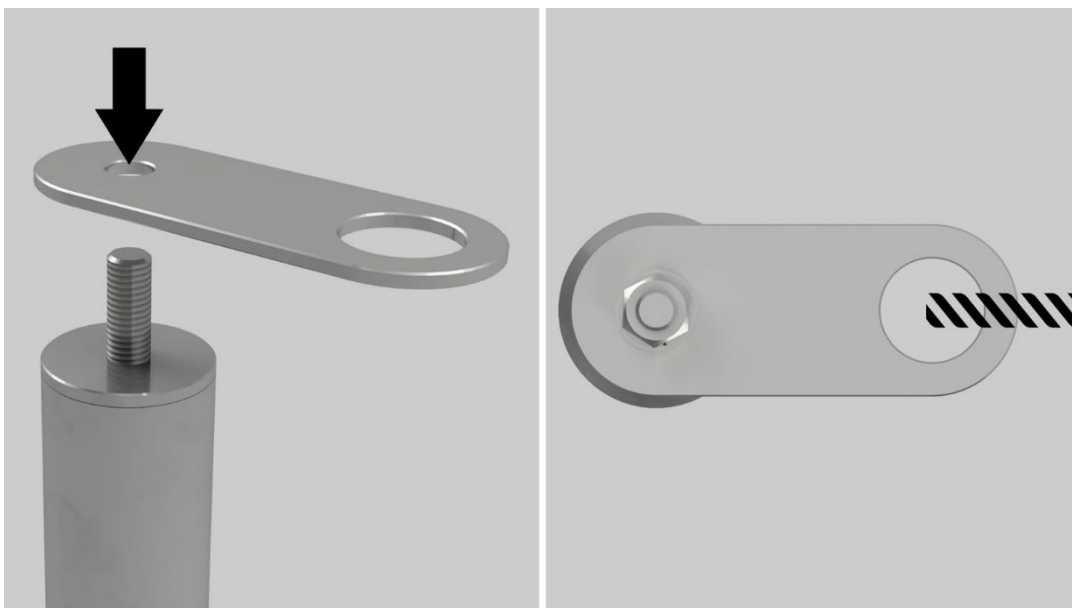
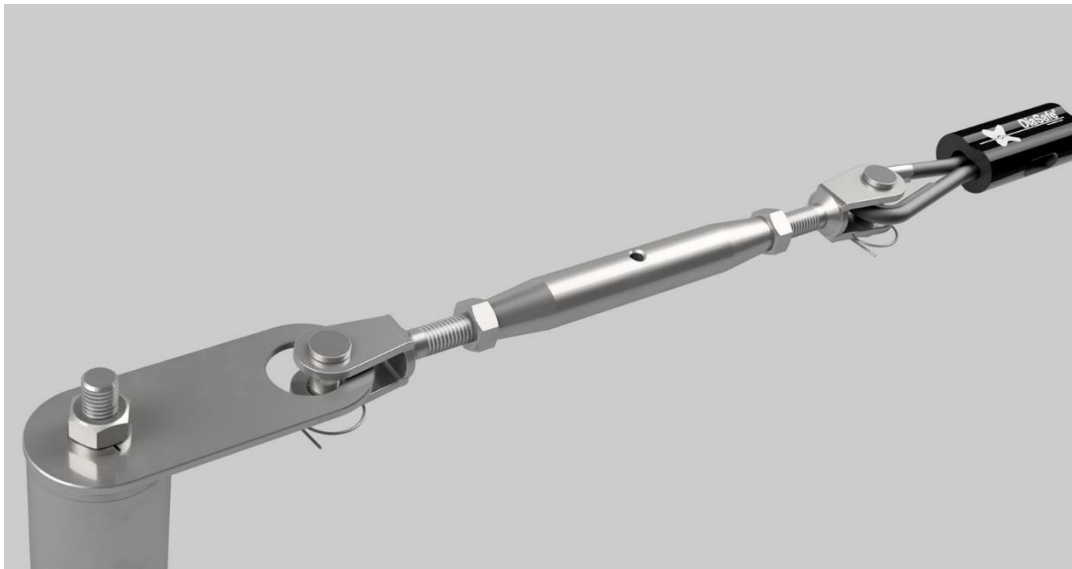

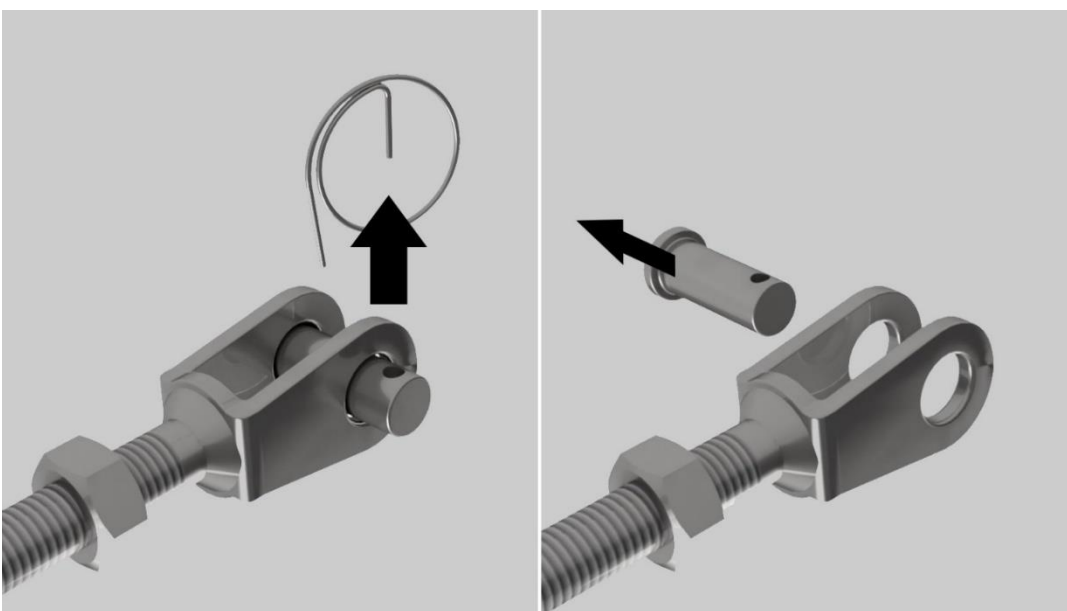
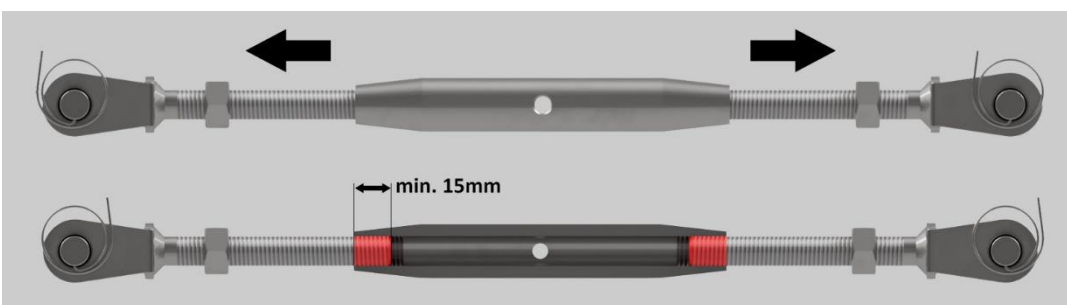
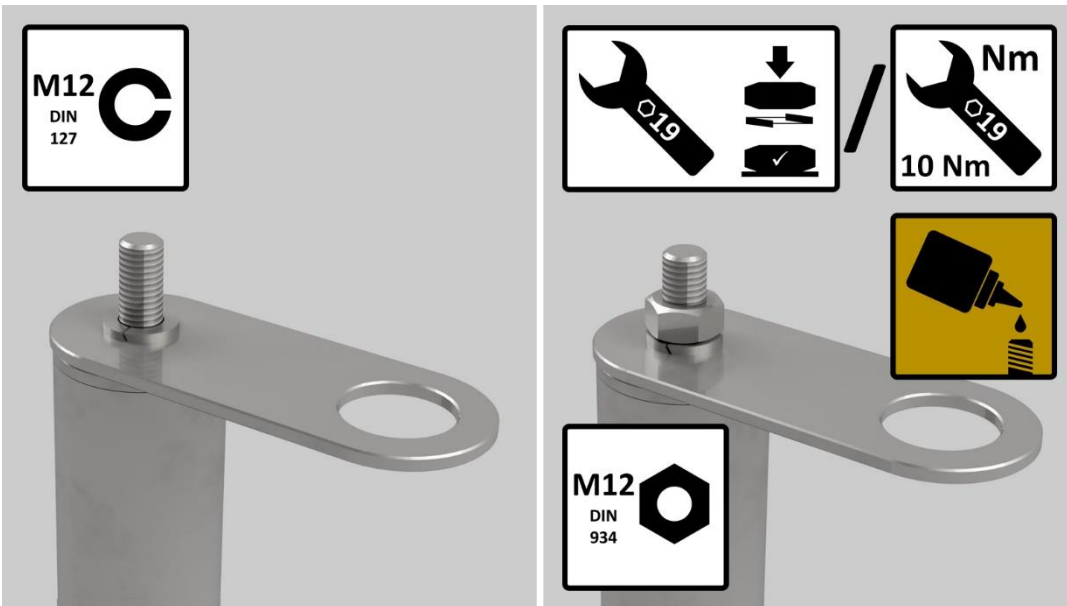

GLIDE SYSTEM | C



GLIDE SYSTEM | C

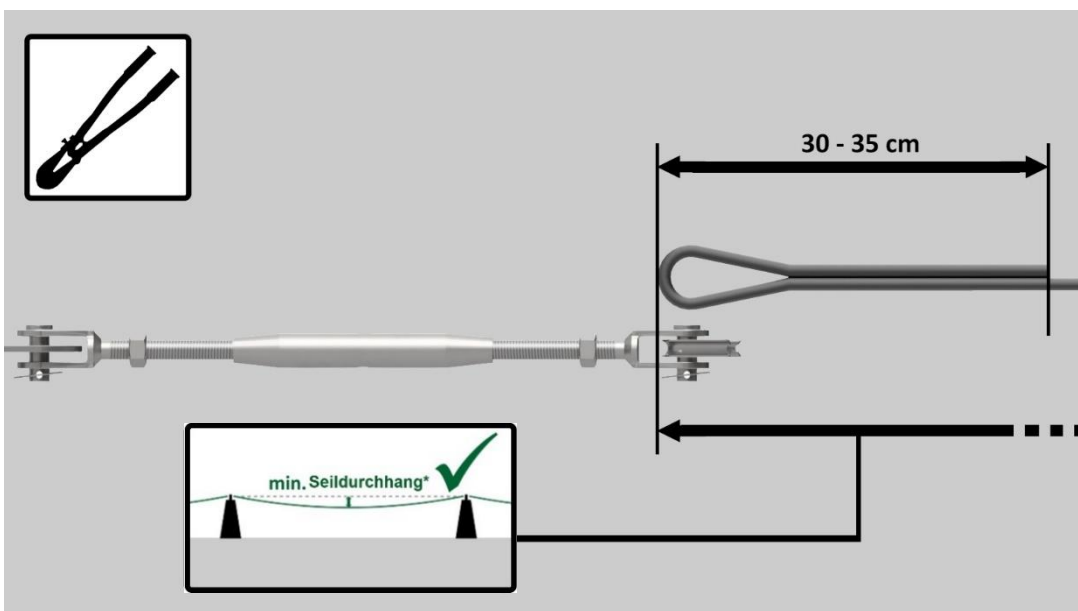
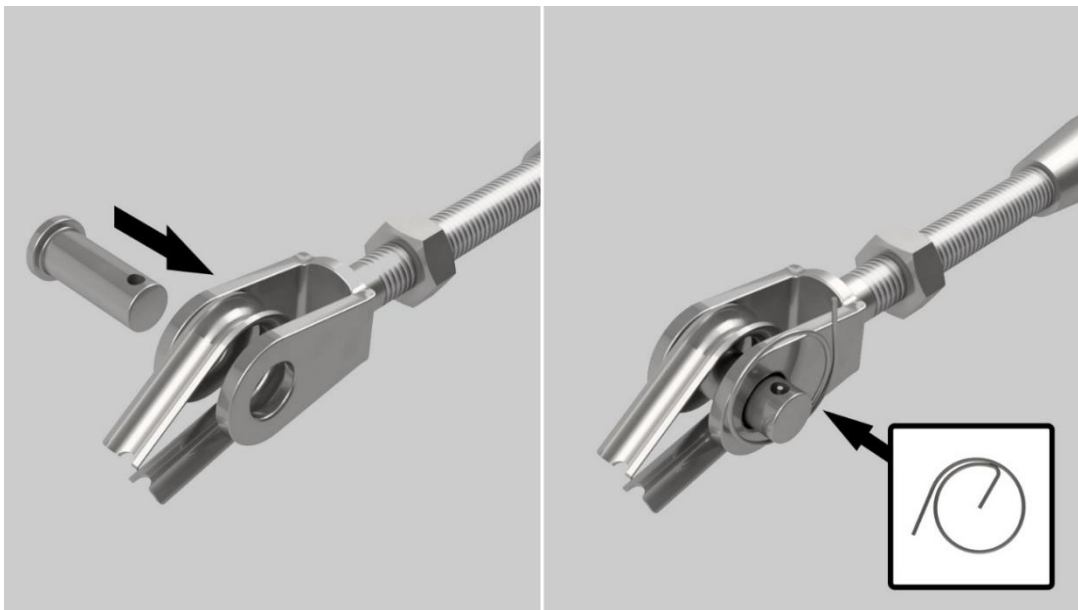
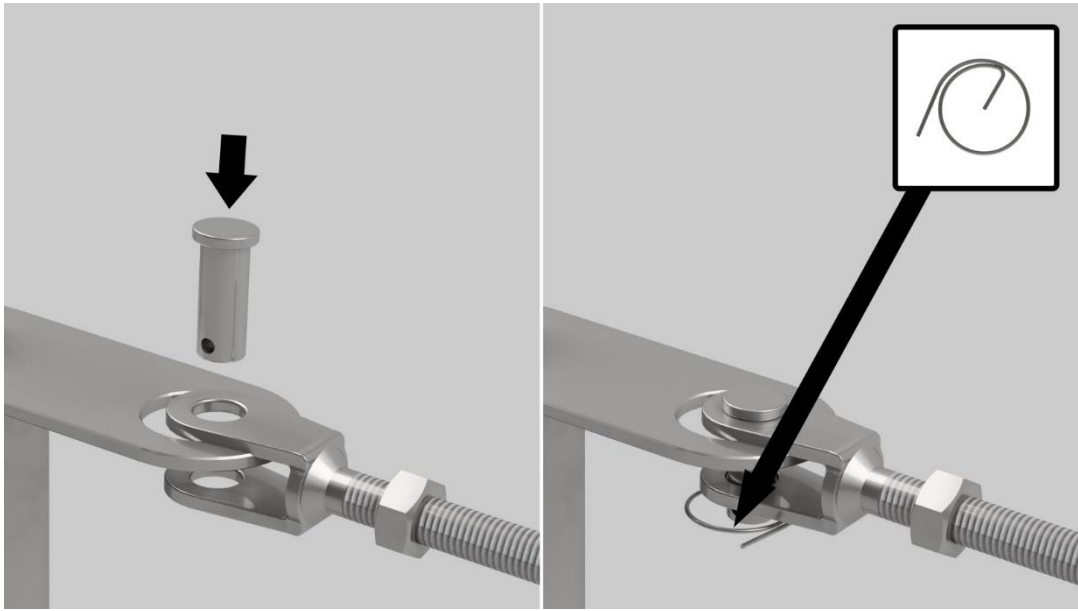

* see page 5 / Siehe Seite 5 / voir page 5 / vedi pagina 5 / Véase la página 5 / lásd 5. oldal

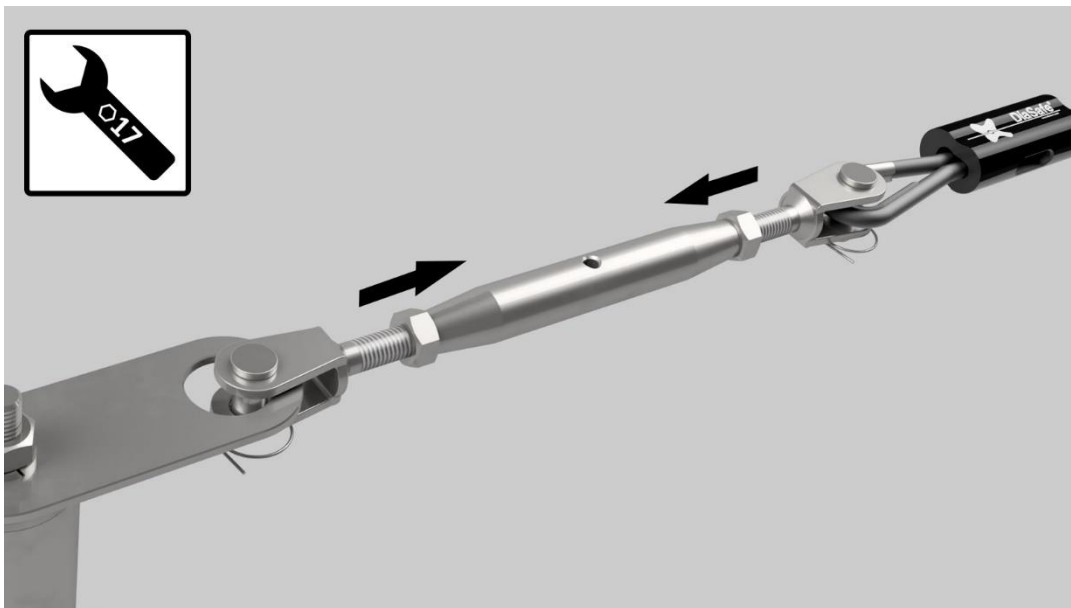
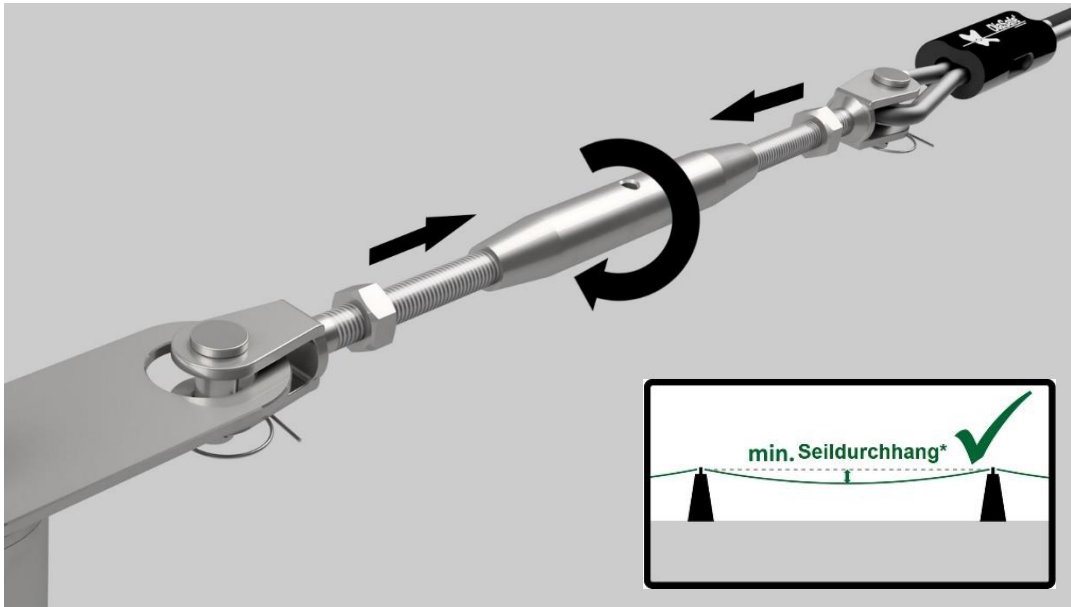

OPTIONAL 3

T-connection / T-Verbindung / T-connection / incrocio a T / Conexión en T/ „T” elágazás

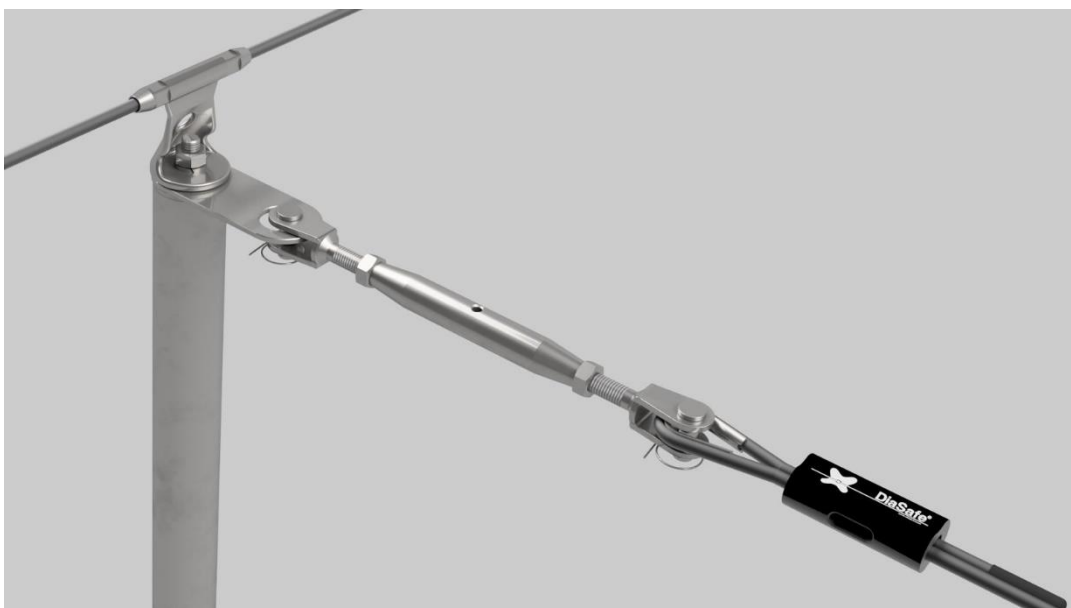

* see page 5 / Siehe Seite 5 / voir page 5 / vedi pagina 5 / Véase la página 5 / lásd 5. oldal



GLIDE SYSTEM | C

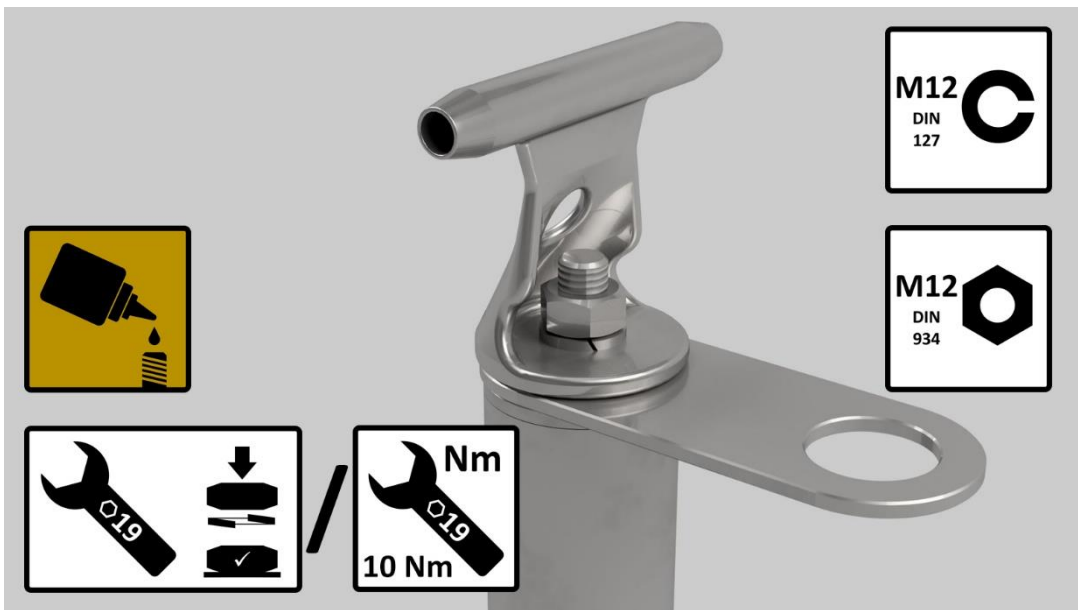
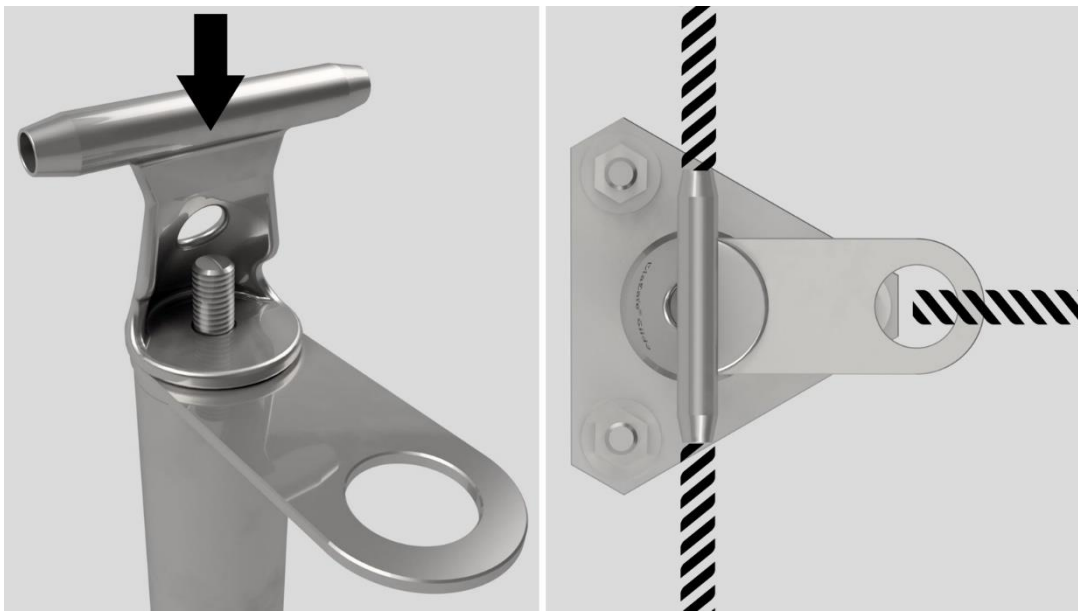
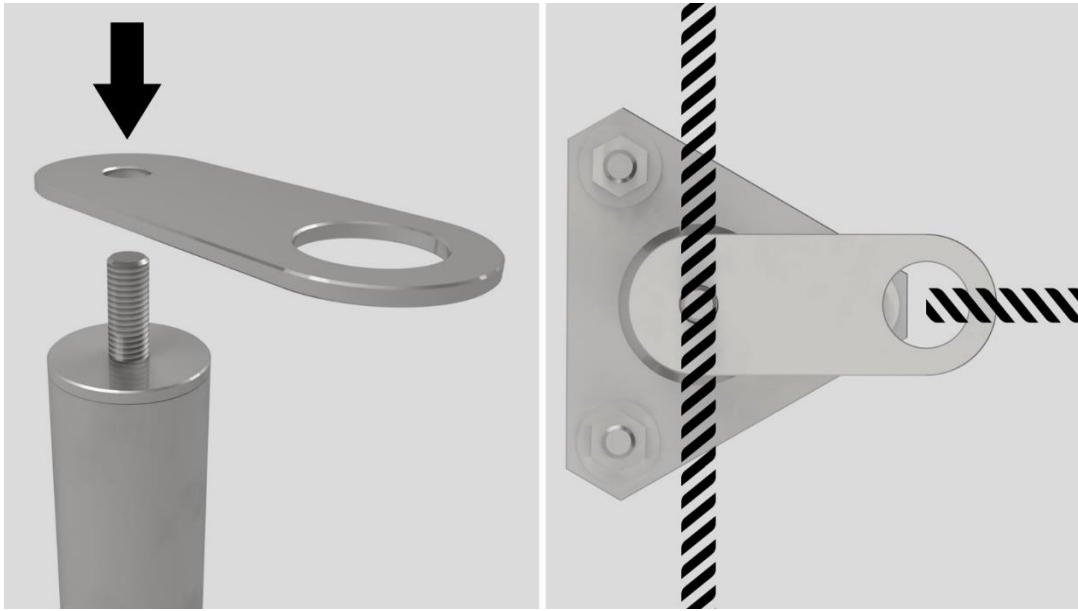

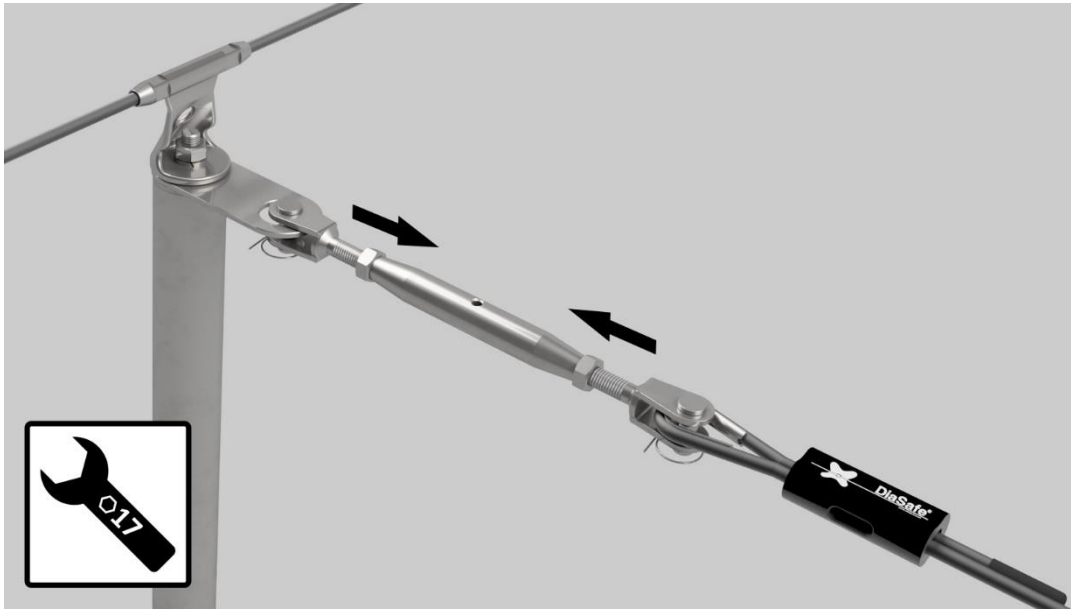

GLIDE SYSTEM | C



DiaGlider-Fix

DiaGlider-Fix additional installation / DiaGlider-Fix nachträglicher Einbau / Installazione addizionale della navetta DiaGlider-Fix / Installation postérieure du DiaGlider-Fix avec mousqueton / Montaje adicional del carro DiaGlider-Fix / DiaGlider-Fix utólagos beépítése – C1 | C2 | C3 | C4

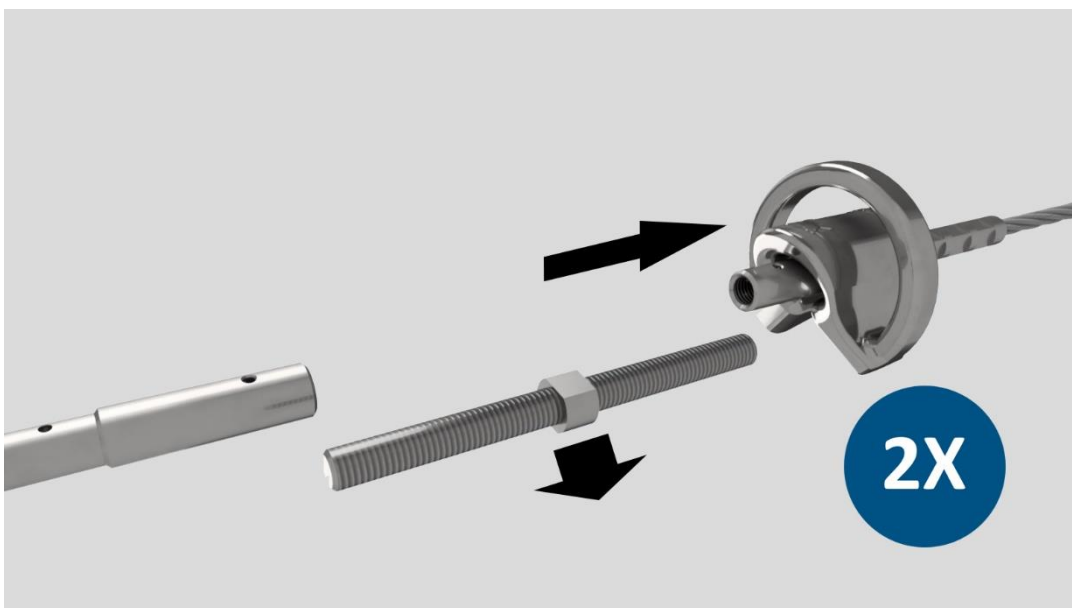
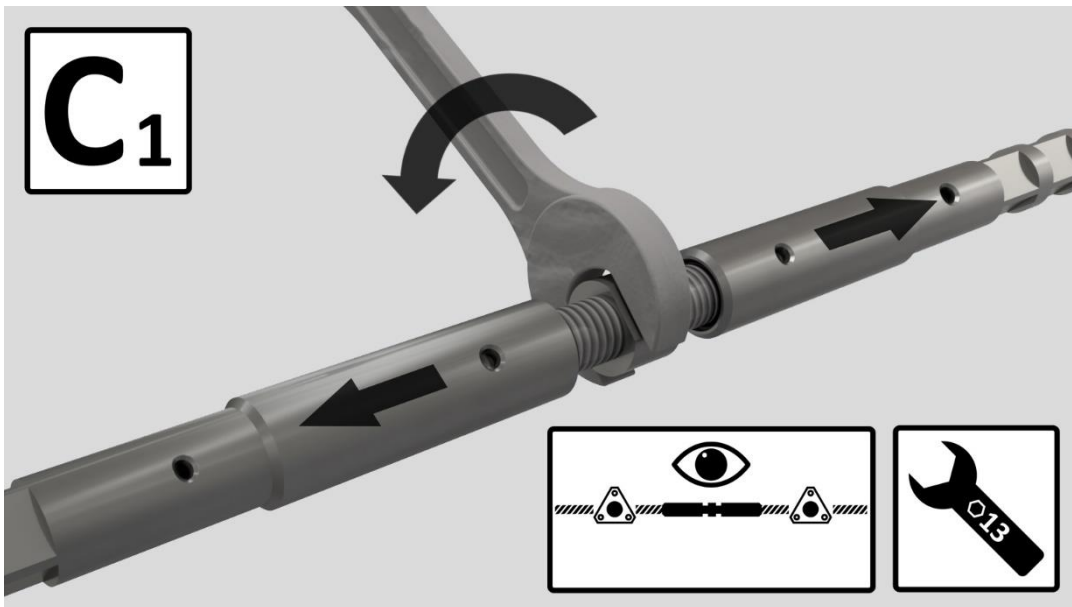
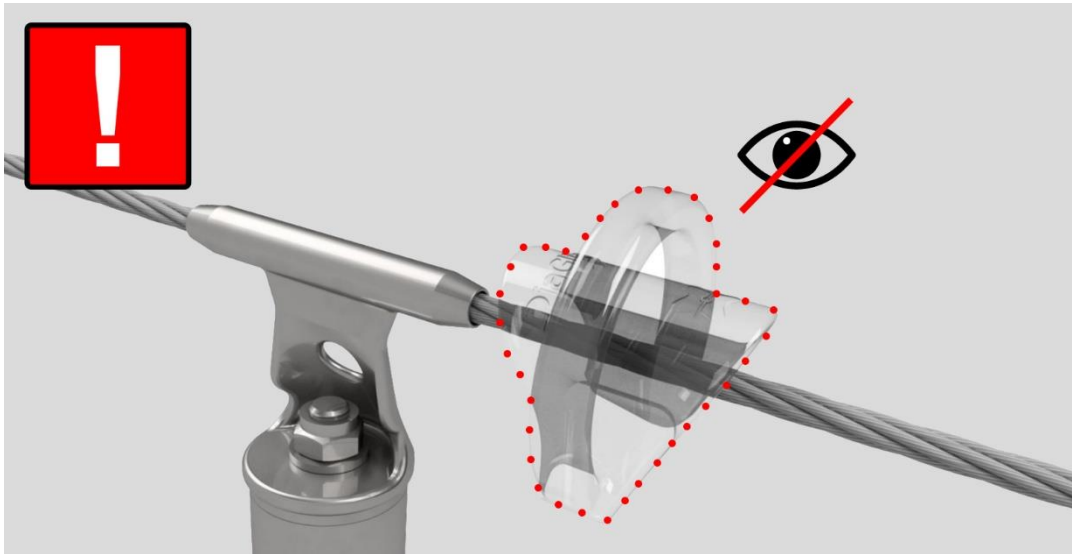

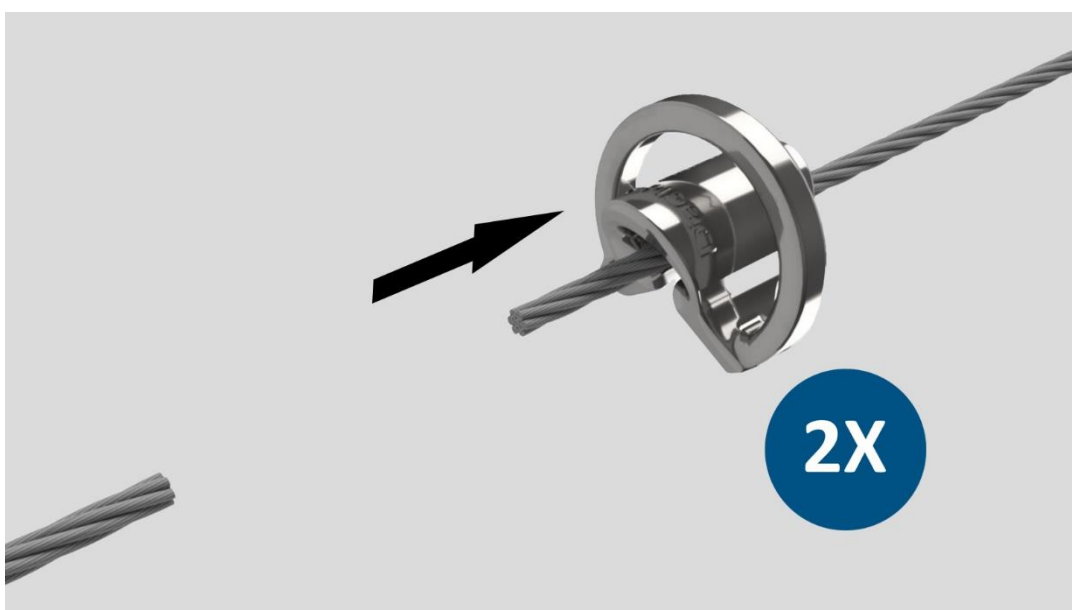
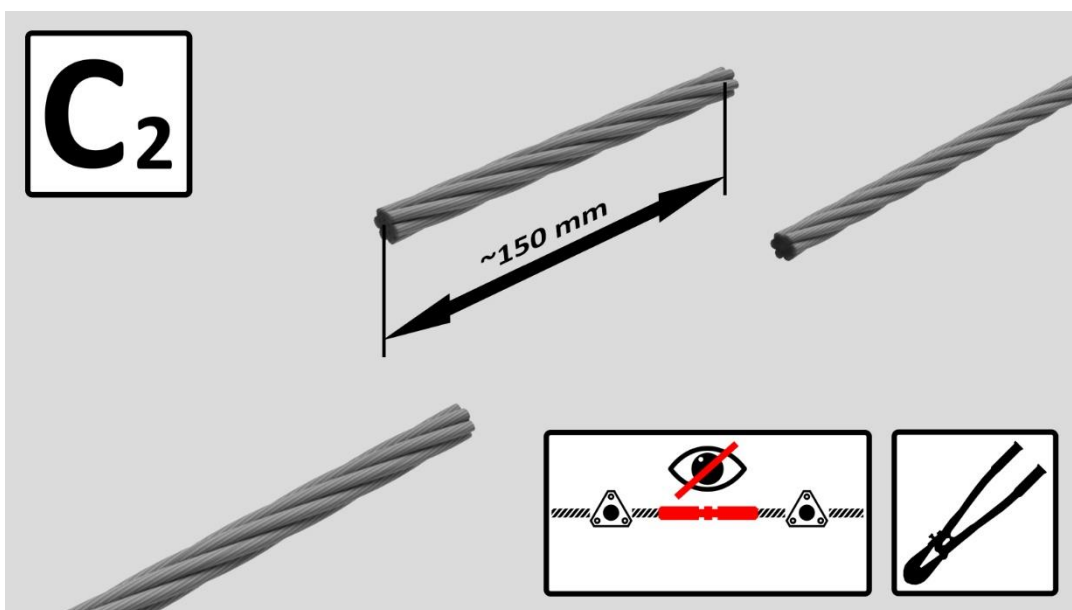
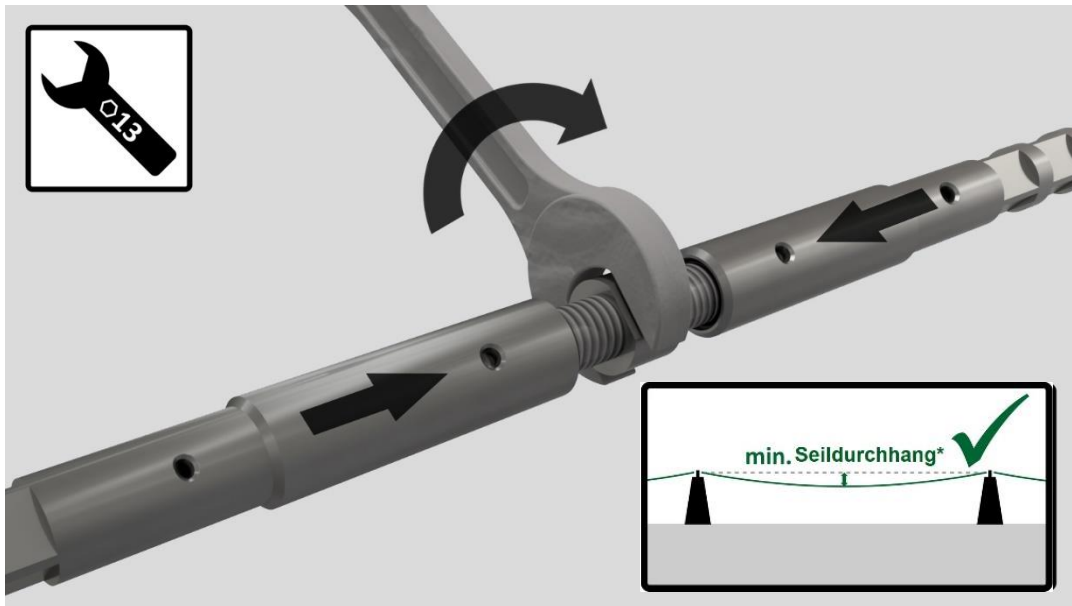

* see page 5 / Siehe Seite 5 / voir page 5 / vedi pagina 5 / Véase la página 5 / lásd 5. oldal



GLIDE SYSTEM | C

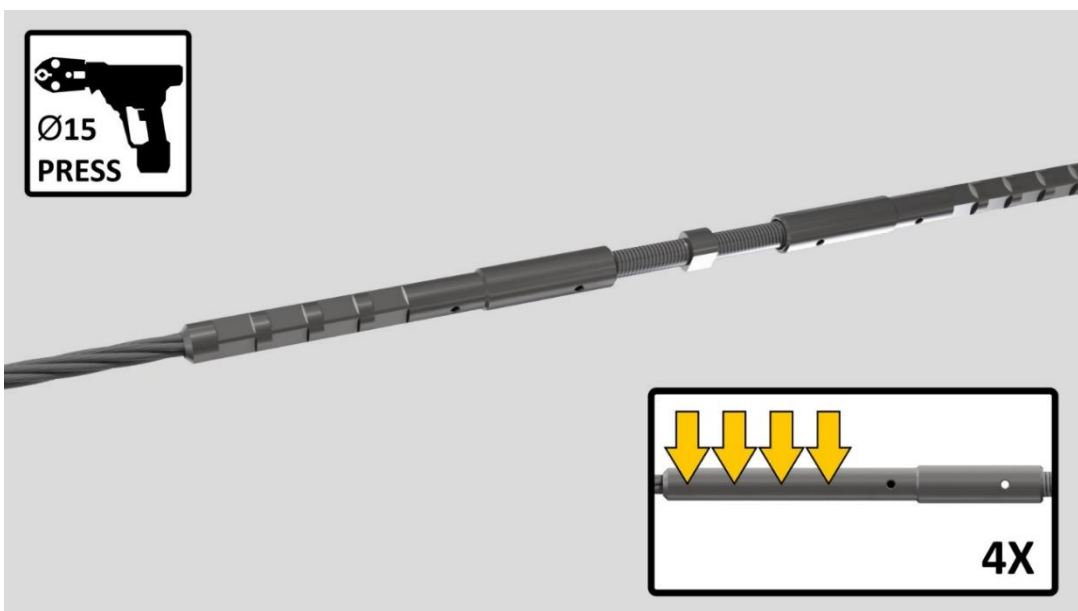
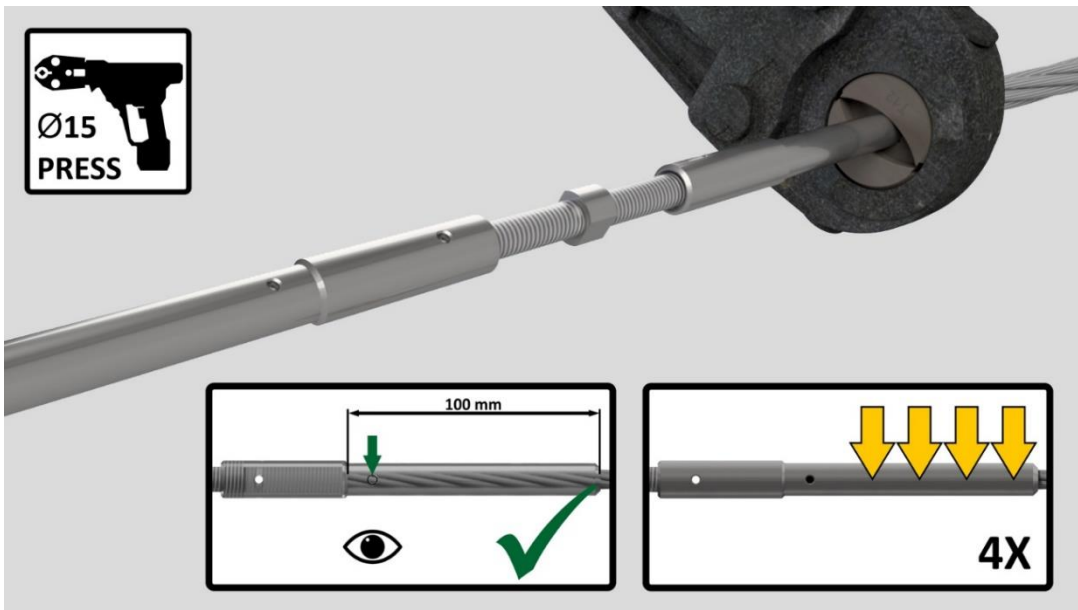
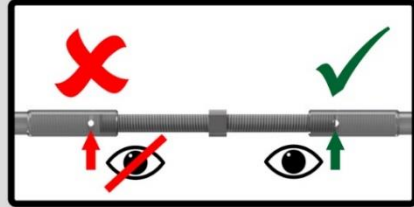
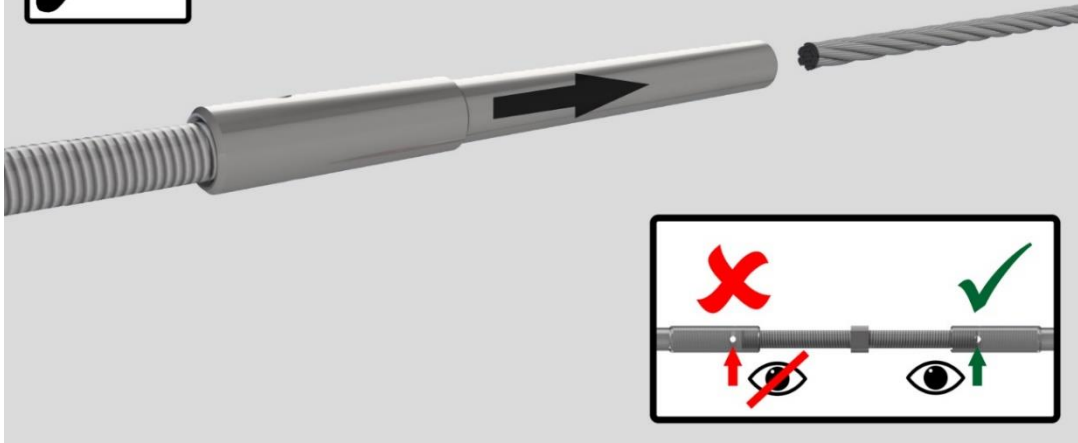

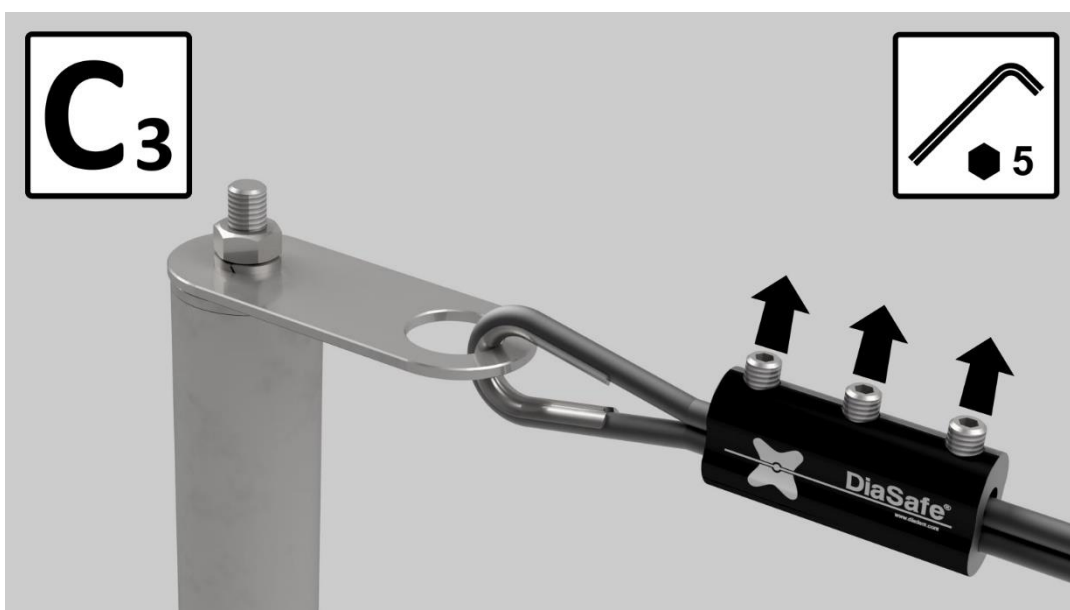
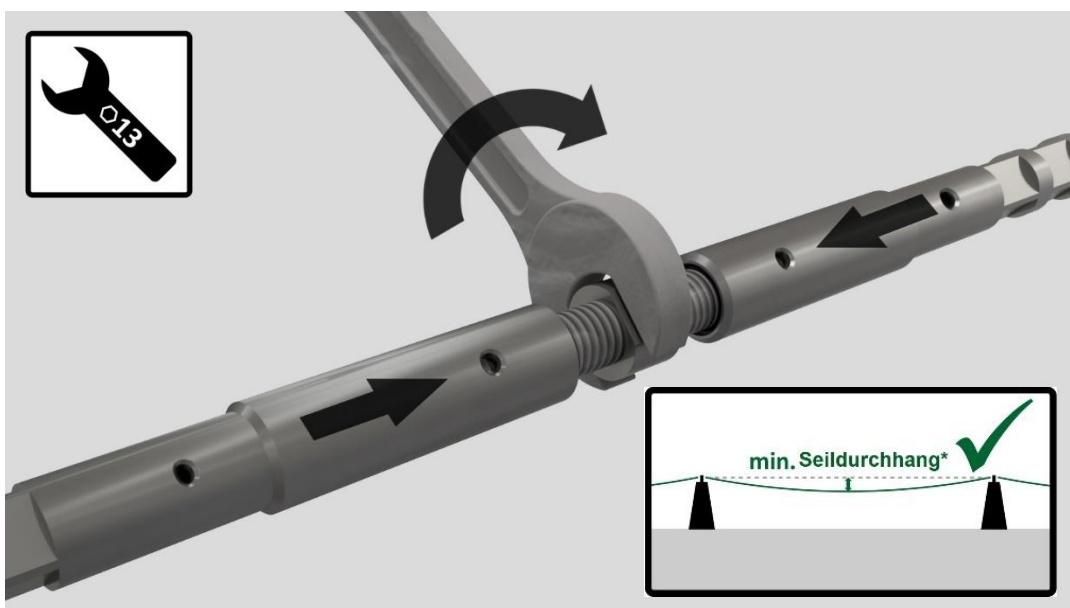
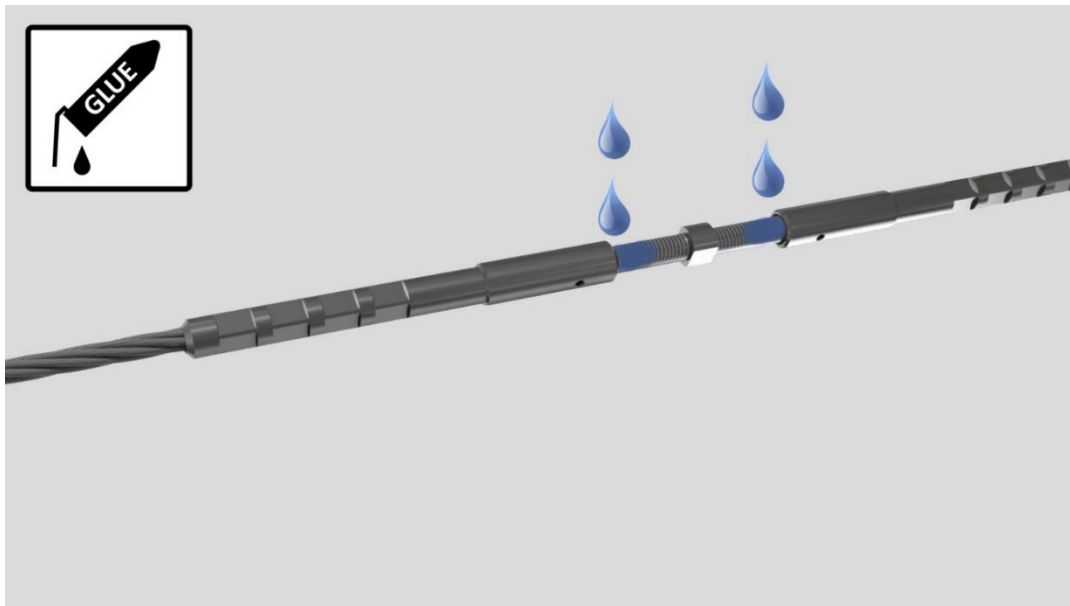

GLIDE SYSTEM | C

* see page 5 / Siehe Seite 5 / voir page 5 / vedi pagina 5 / Véase la página 5 / lásd 5. oldal



GLIDE SYSTEM | C

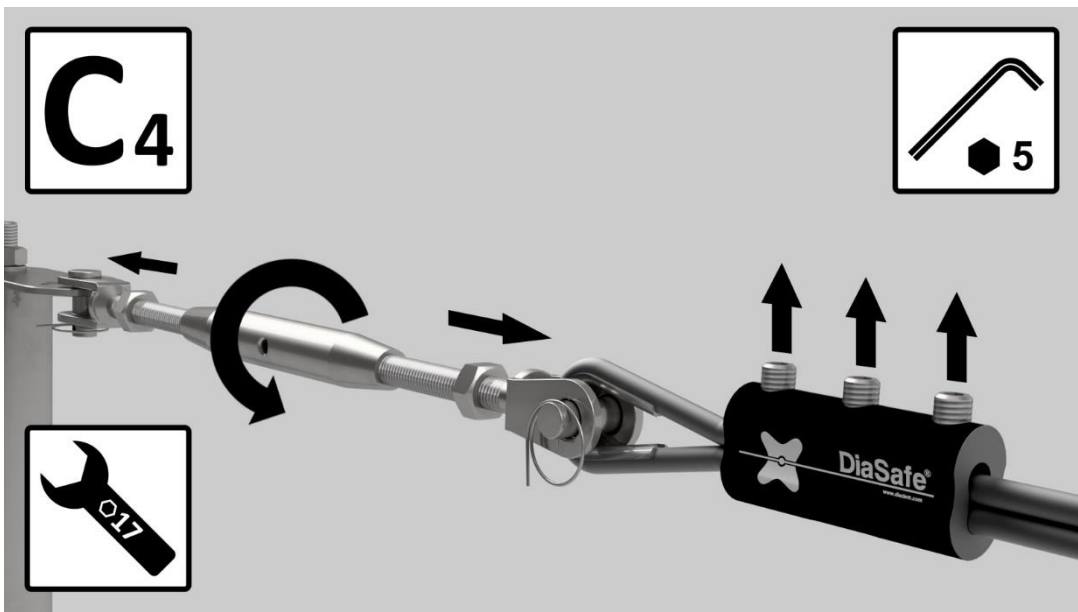
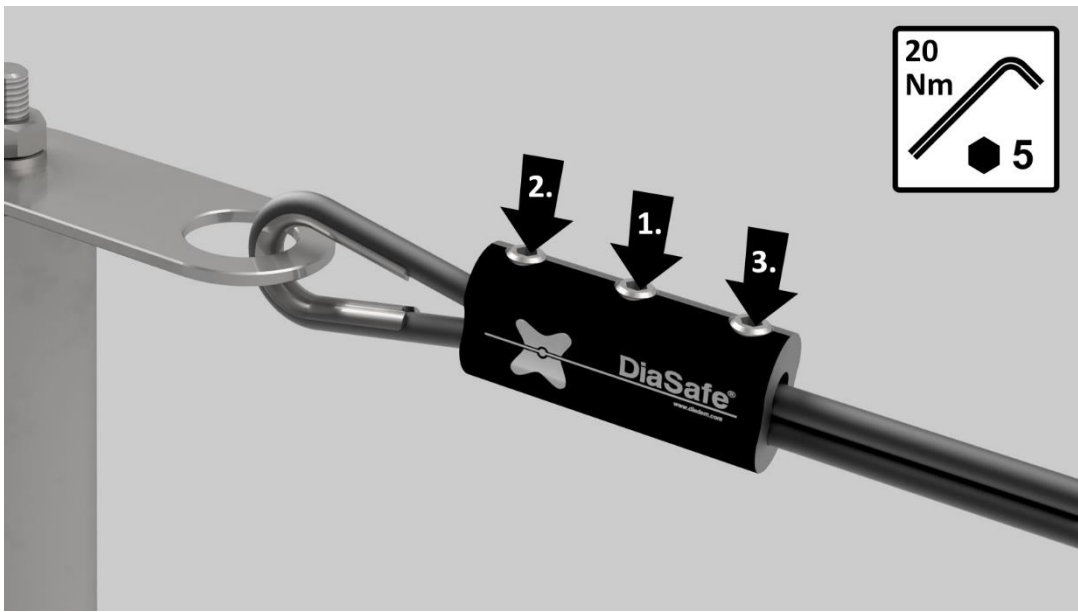
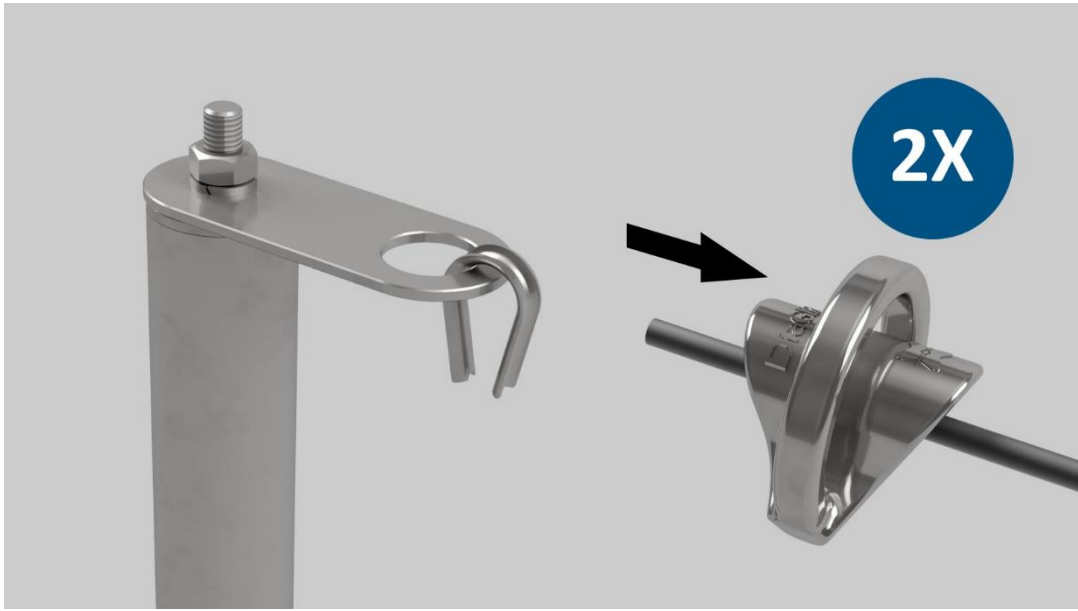

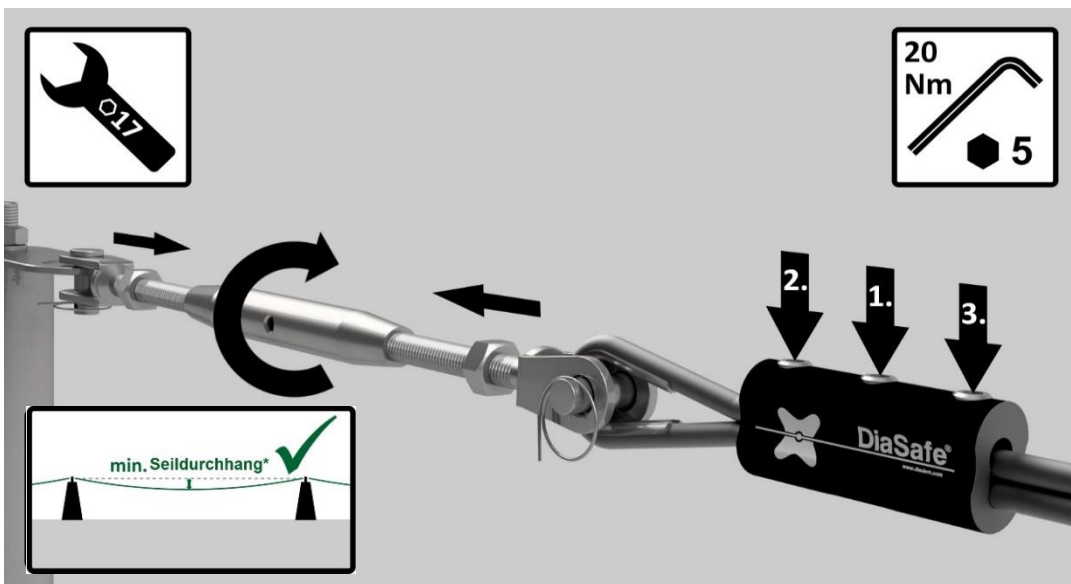
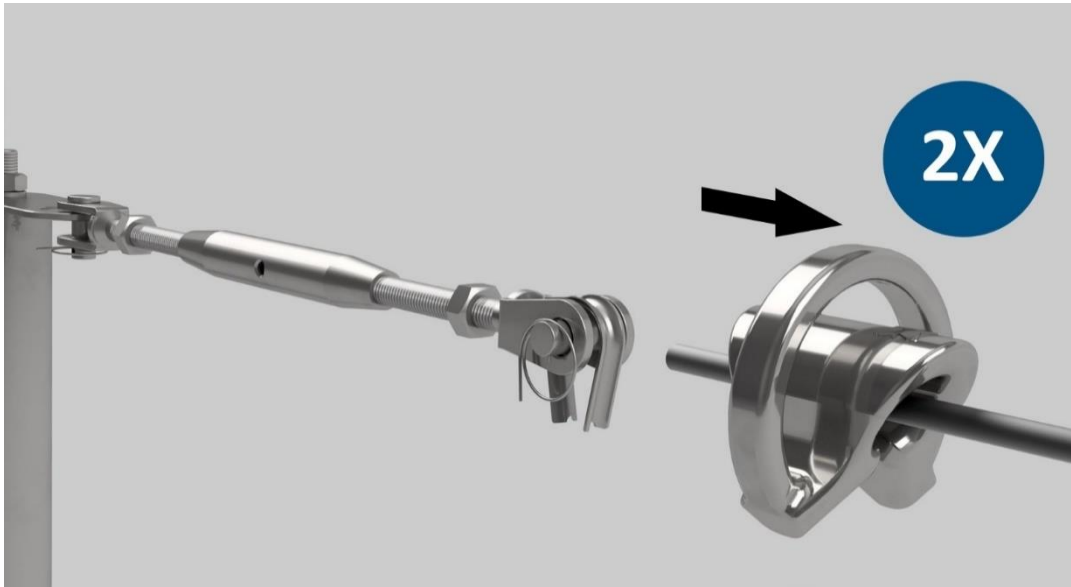

* see page 5 / Siehe Seite 5 / voir page 5 / vedi pagina 5 / Véase la página 5 / lásd 5. oldal

Position of the DiaGlider-Fix out of use / Die Lagerposition des DiaGlider-Fix Durchlaufelementes / Posizione della navetta DiaGlider-Fix quando non è in uso / DiaGlider-Fix avec mousqueton hors d'usage / La posición del carro DiaGlider-Fix cuando no está en uso / DiaGlider-Fix pozíciója használaton kívül

Out of danger zone / Ausserhalb dem Gefahrenbereich / hors de zone de danger / al di fuori della zona del pericolo / Fuera de la zona de peligro / veszélyzónán kívül

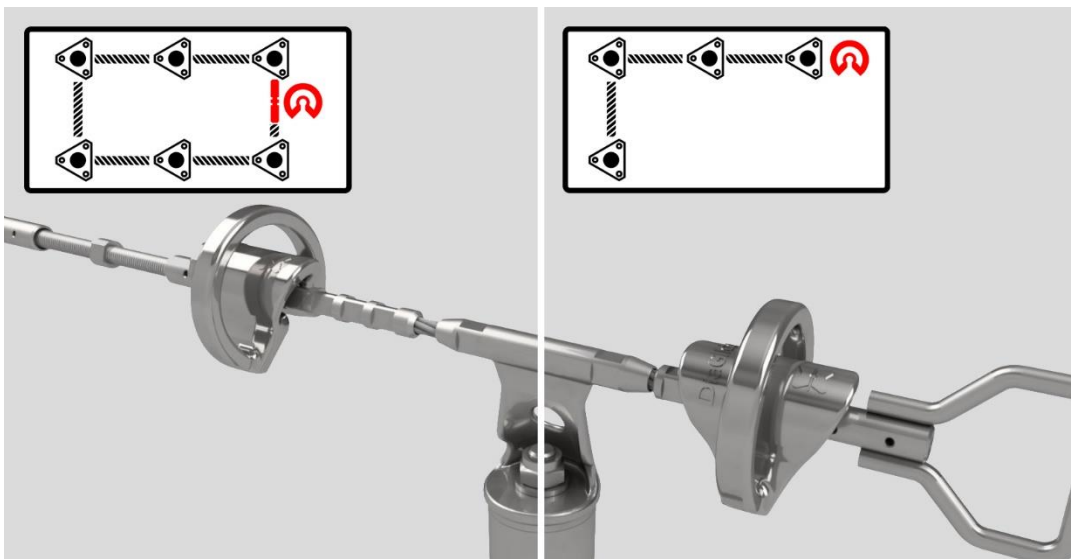



GLIDE SYSTEM

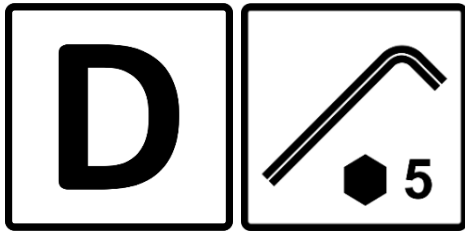
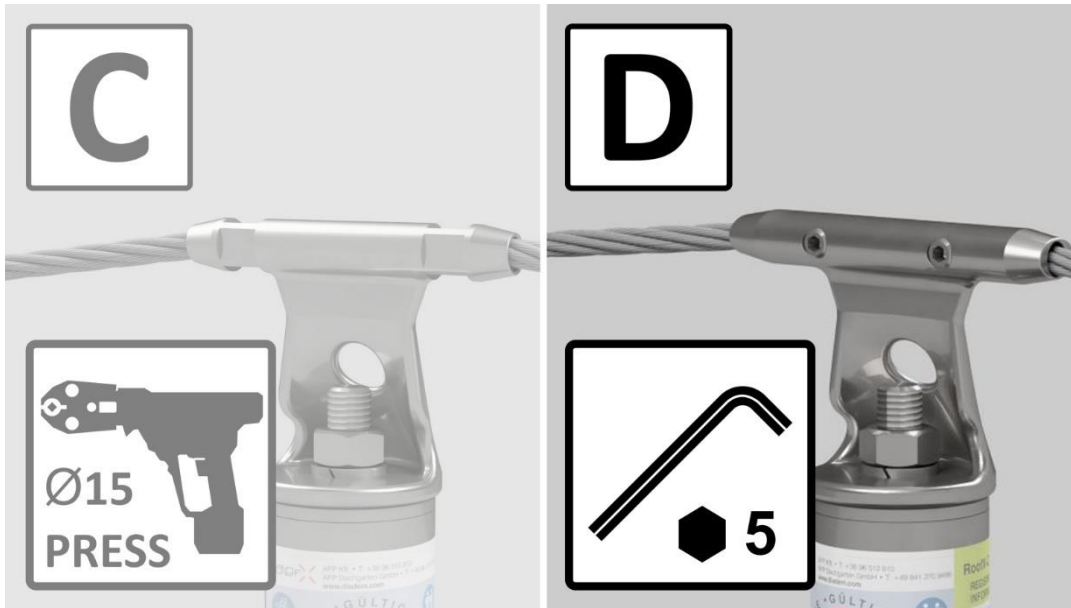

Open linesystem installation (with start- and end posts) / Montageablauf offenes Seilsystem (mit Anfangs- und Endstütze) / Installation d'un système ouvert (avec Start- et Fin potelet) / Montaggio sistema aperto (con supporto iniziale e terminale) / Proceso de montaje del sistema de cable abierto (con soporte de apoyo inicial y final) / Nyílt rendszer telepítése (kezdő- és végoszloppal)

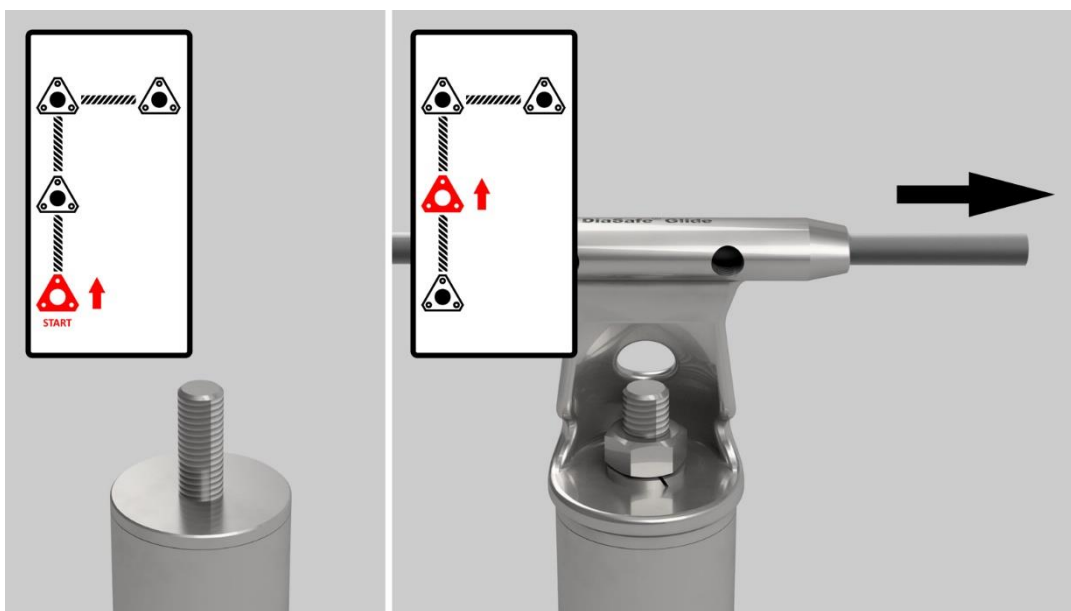

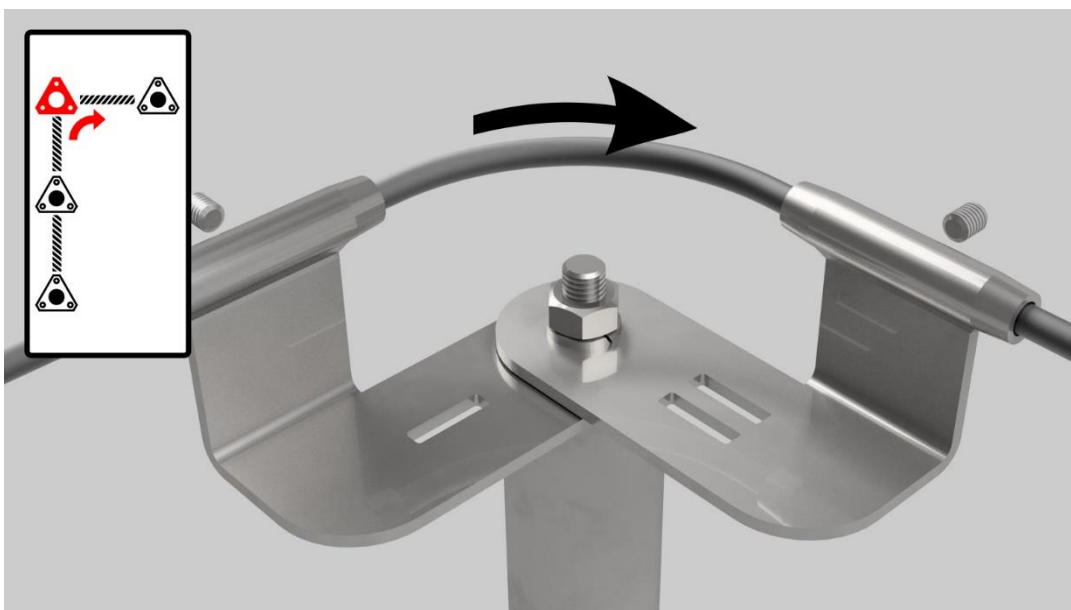
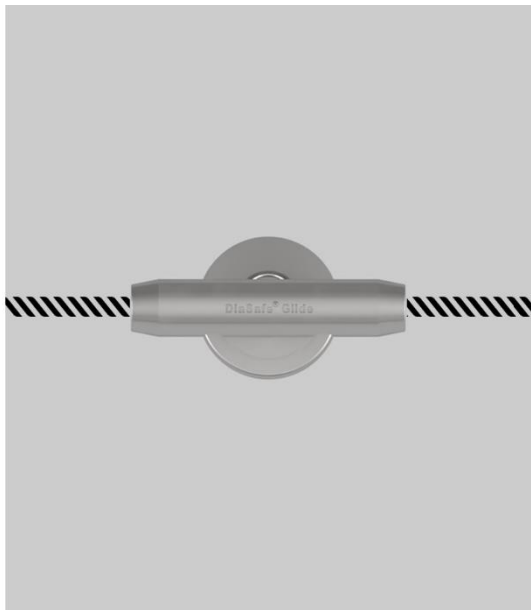

GLIDE SYSTEM | D



GLIDE SYSTEM | D

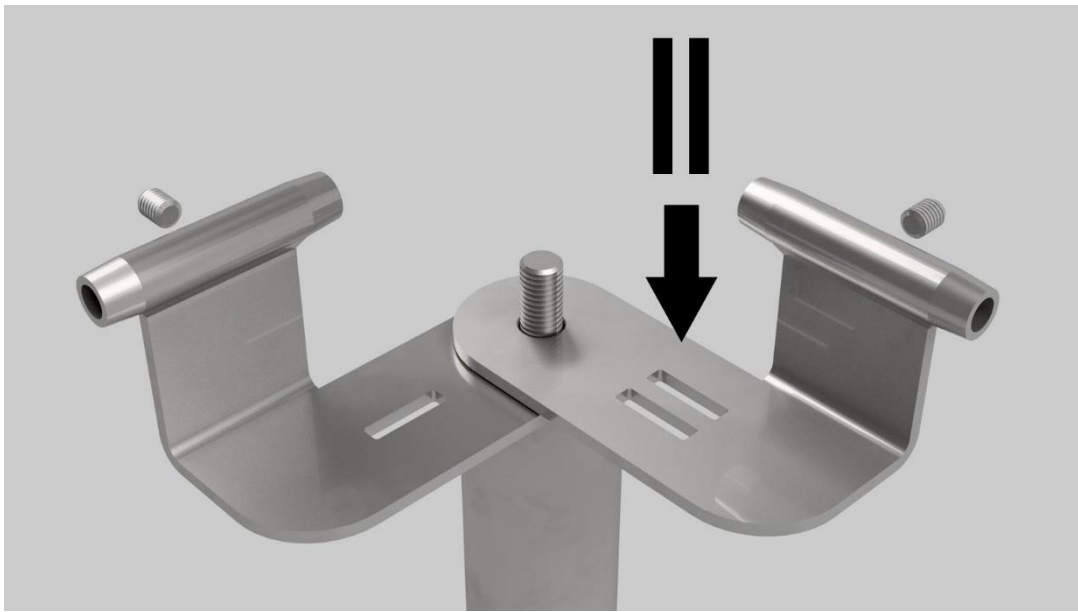
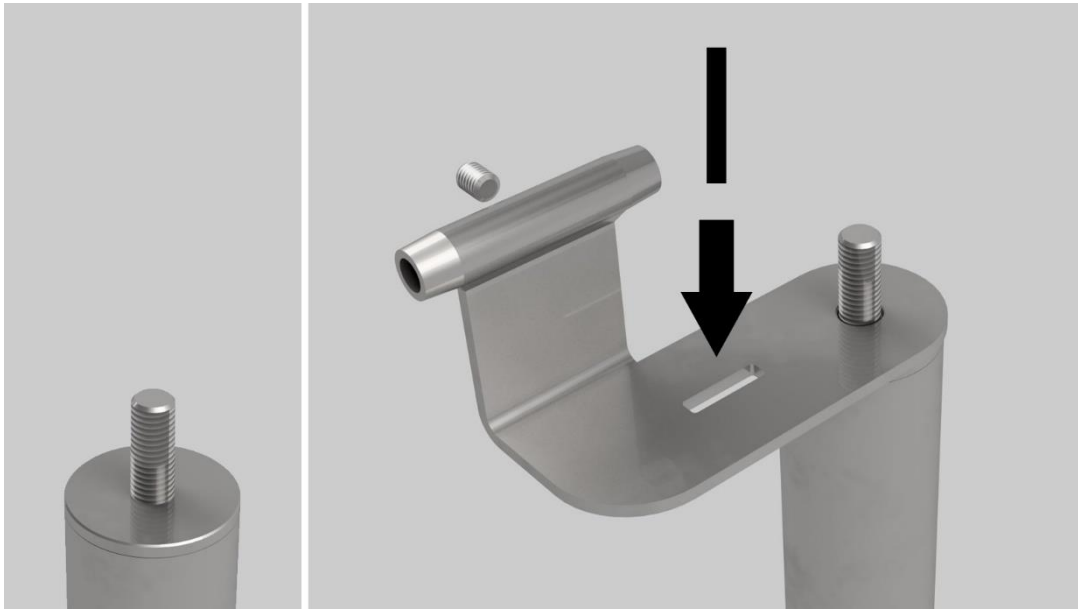

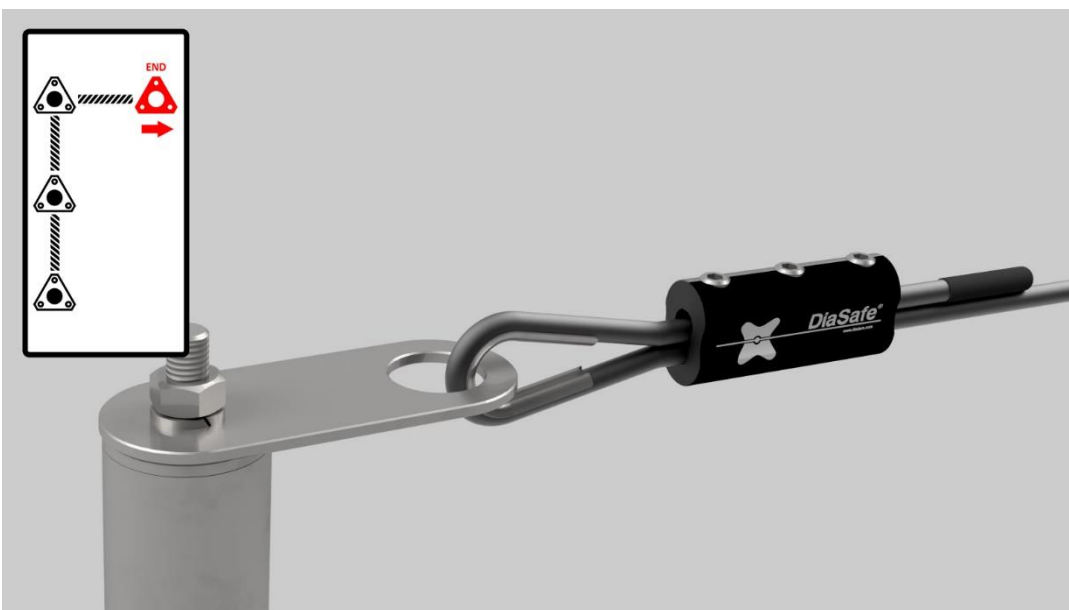
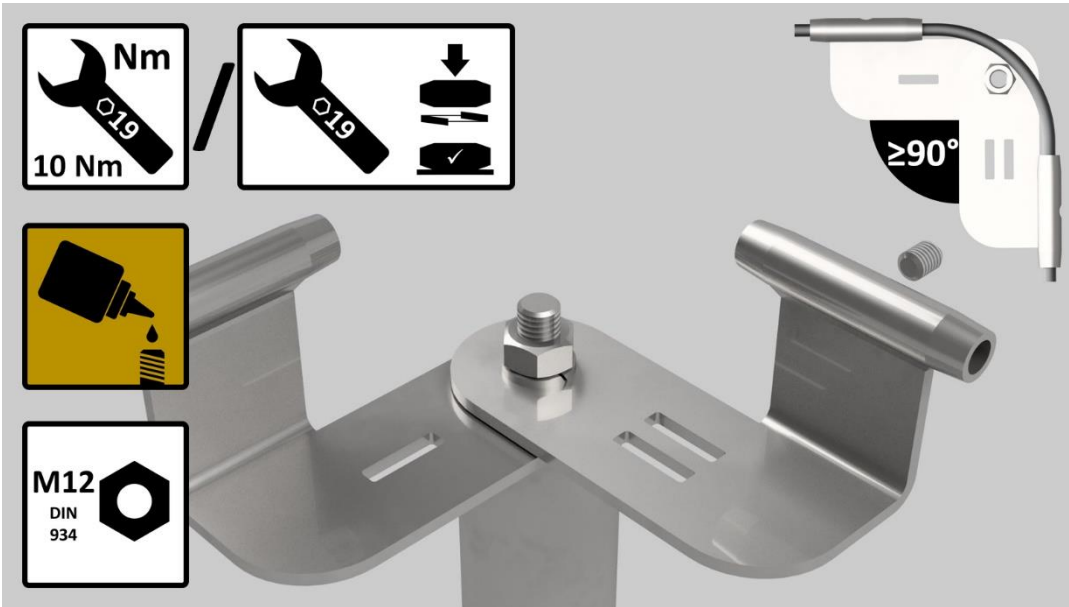

GLIDE SYSTEM | D



GLIDE SYSTEM | D

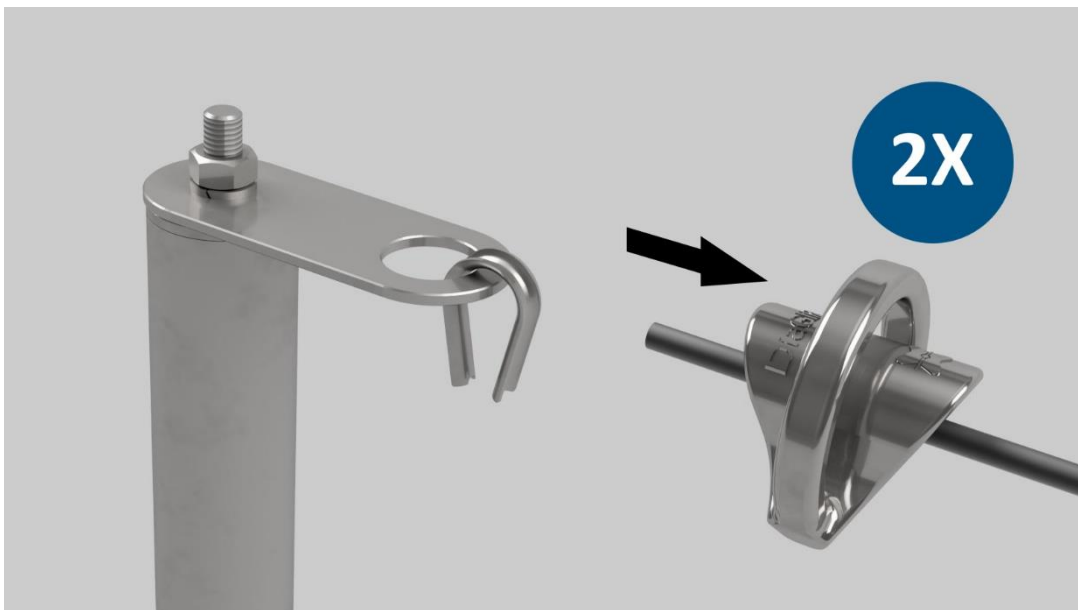
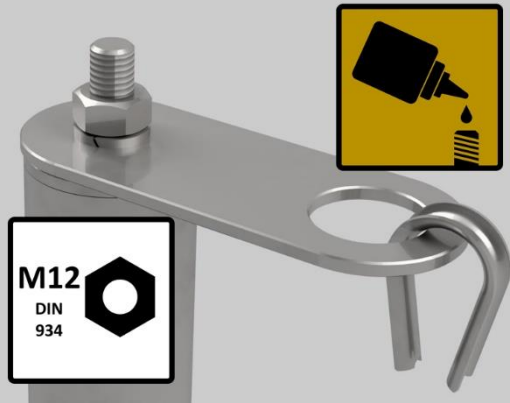
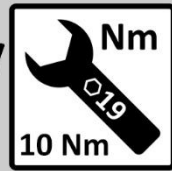
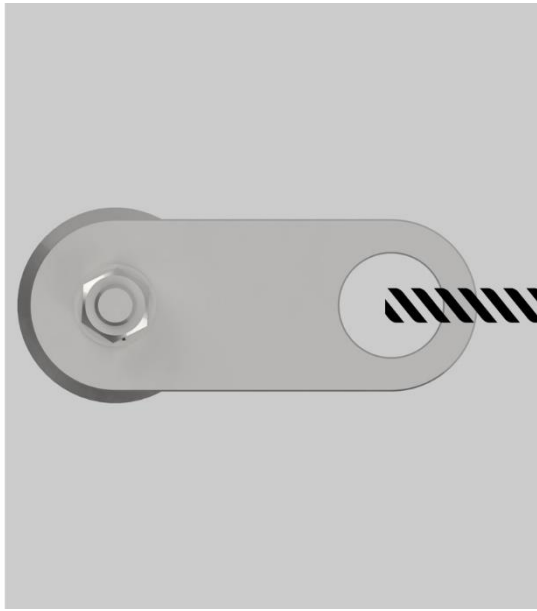
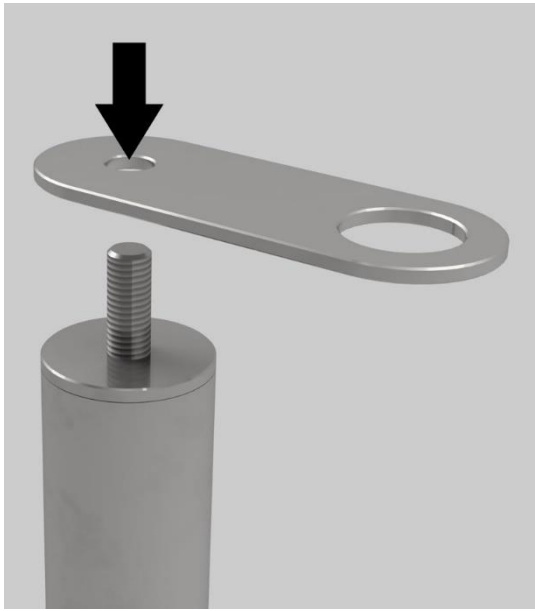

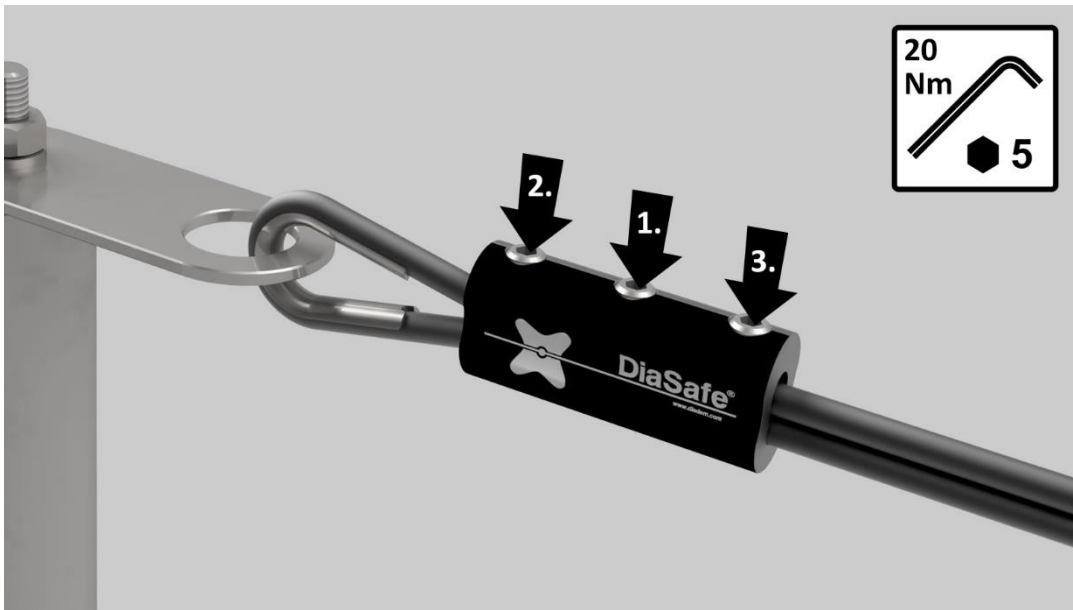
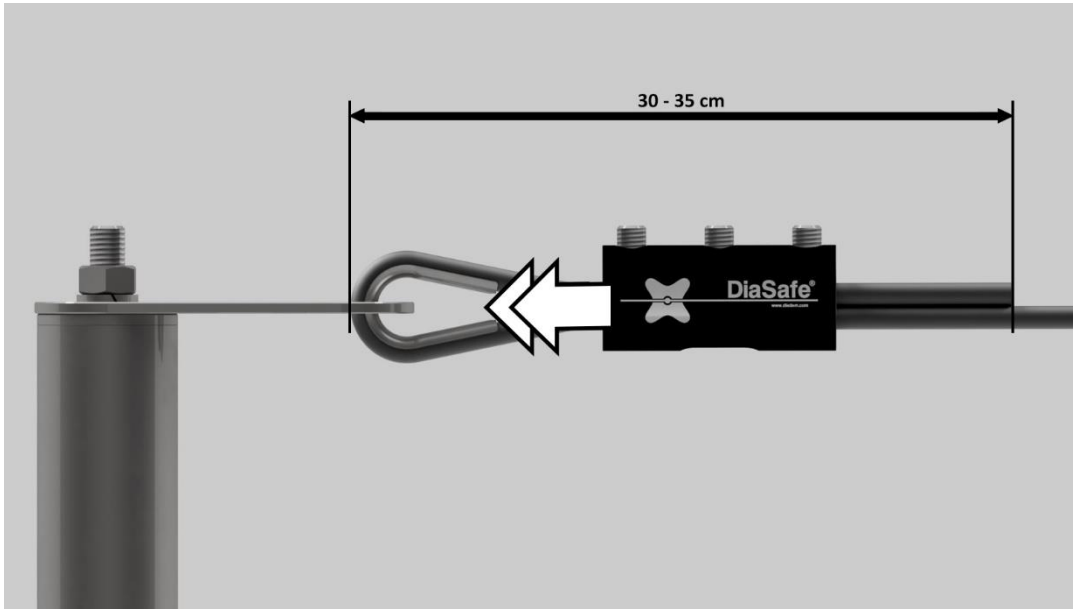

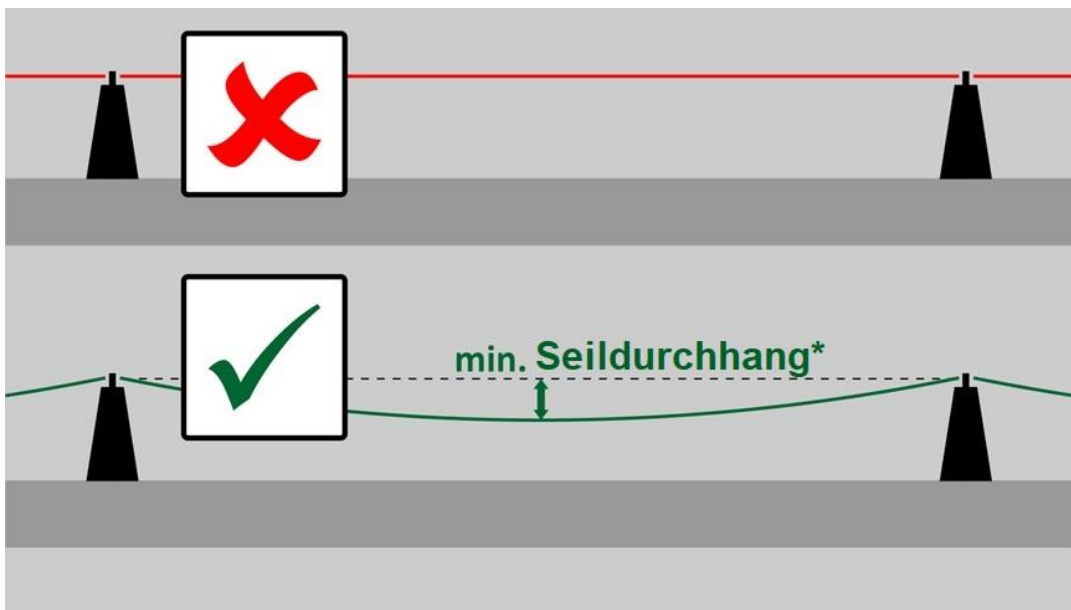

* see page 5 / Siehe Seite 5 / voir page 5 / vedi pagina 5 / Véase la página 5 / lásd 5. oldal

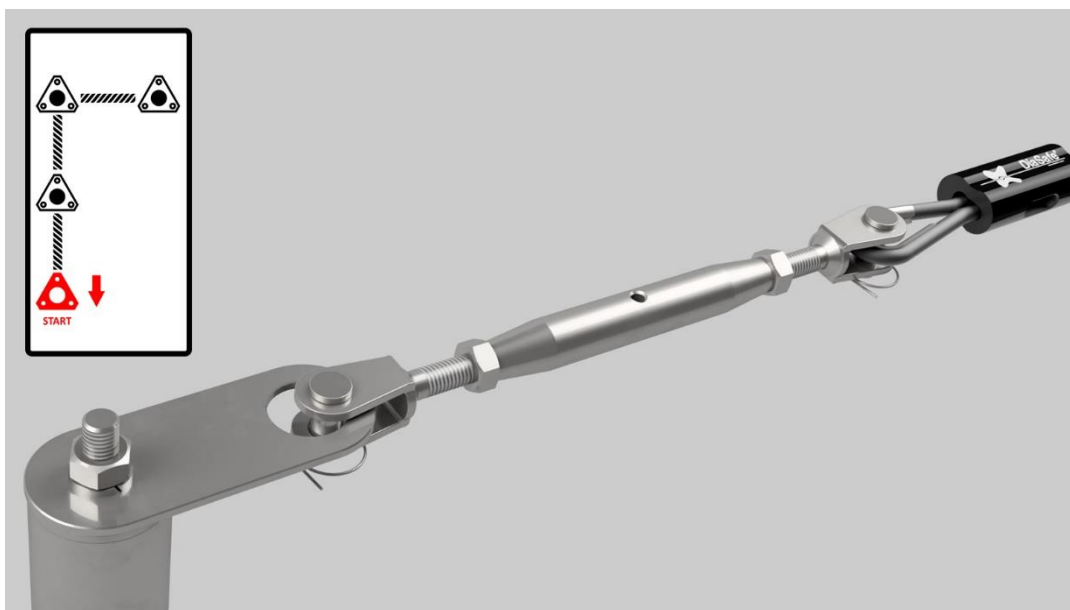
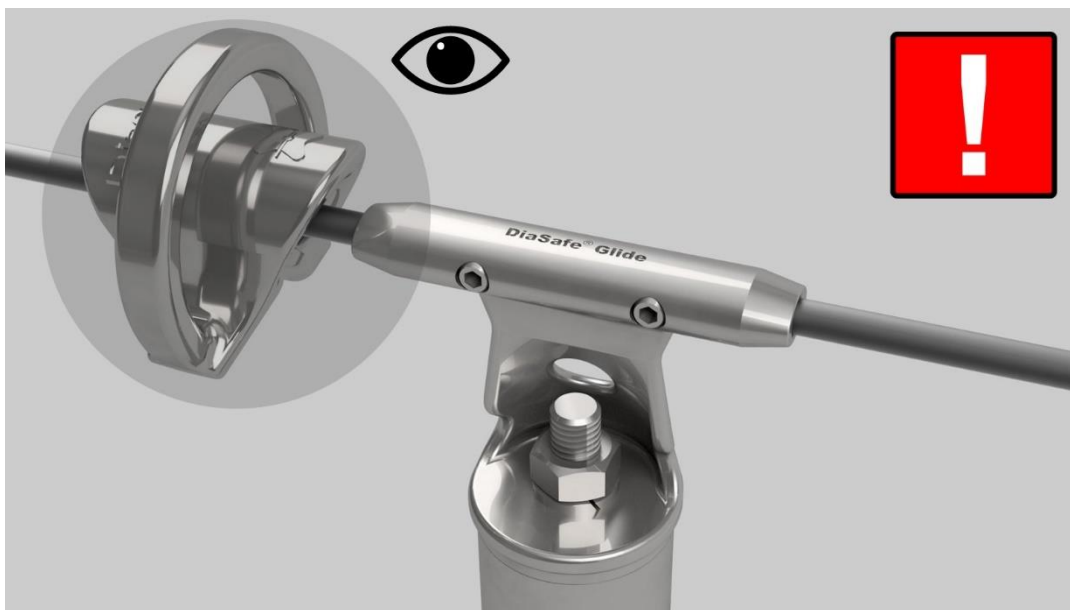

* see page 5 / Siehe Seite 5 / voir page 5 / vedi pagina 5 / Véase la página 5 / lásd 5. oldal



GLIDE SYSTEM | D

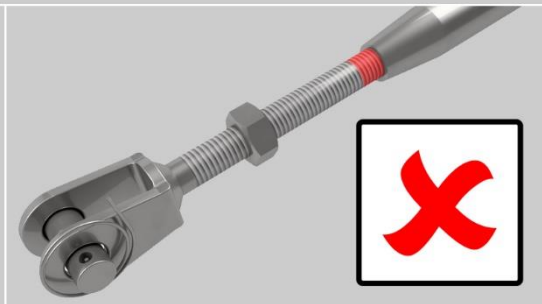
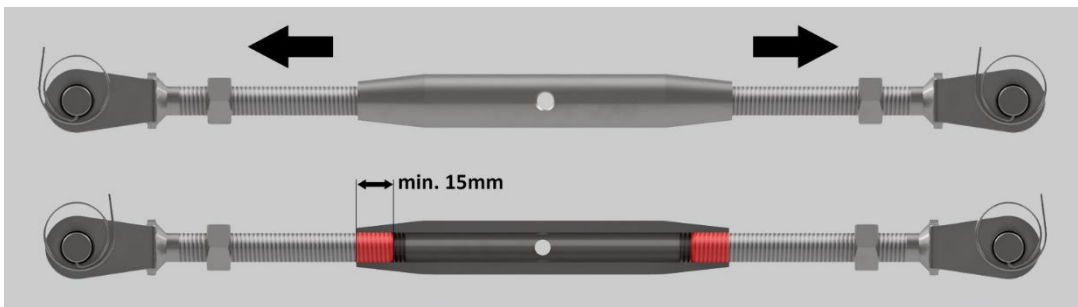
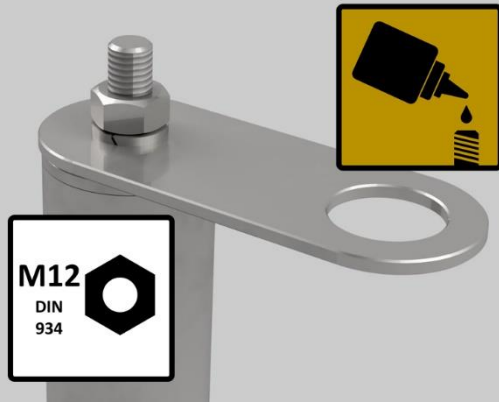
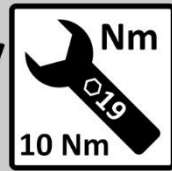
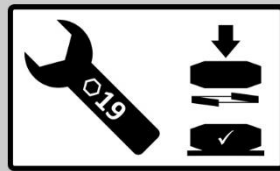
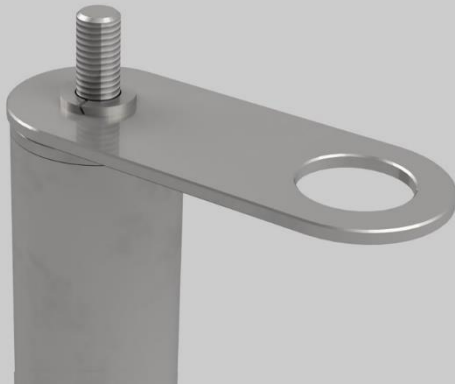
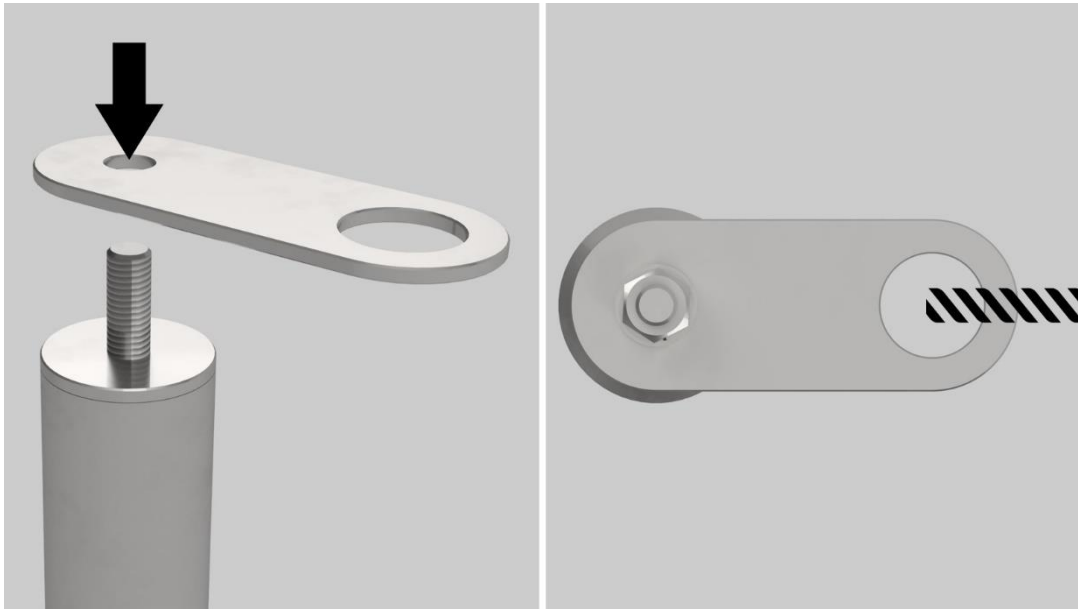

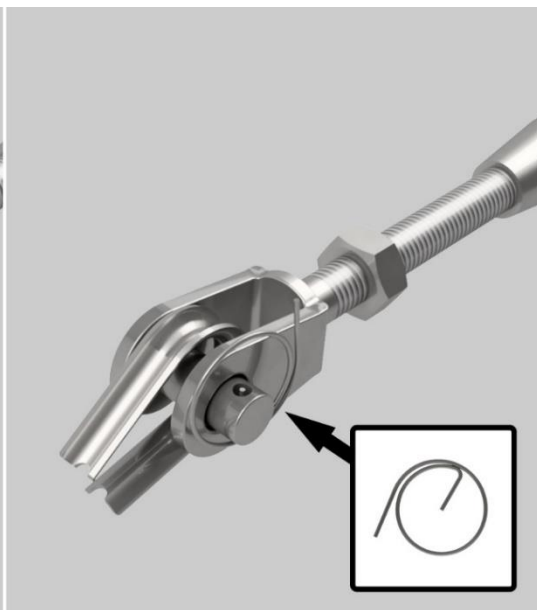
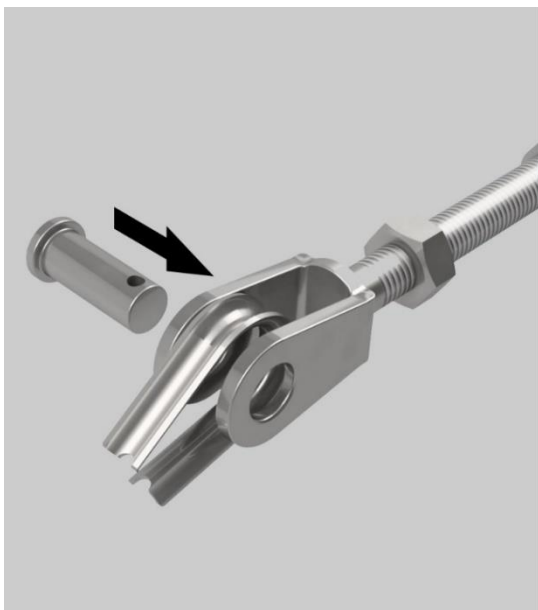
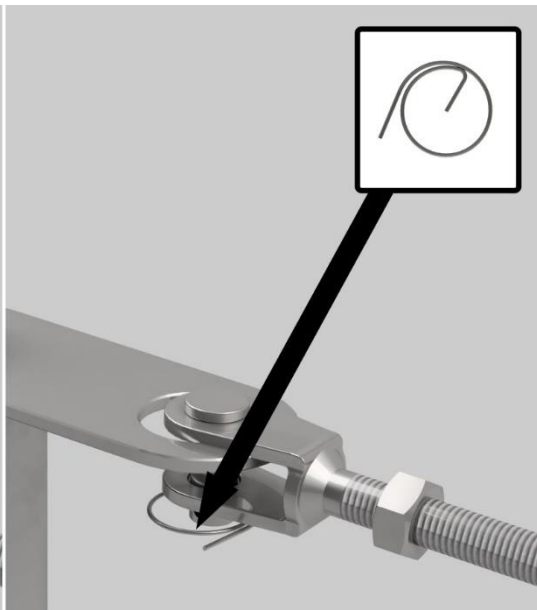
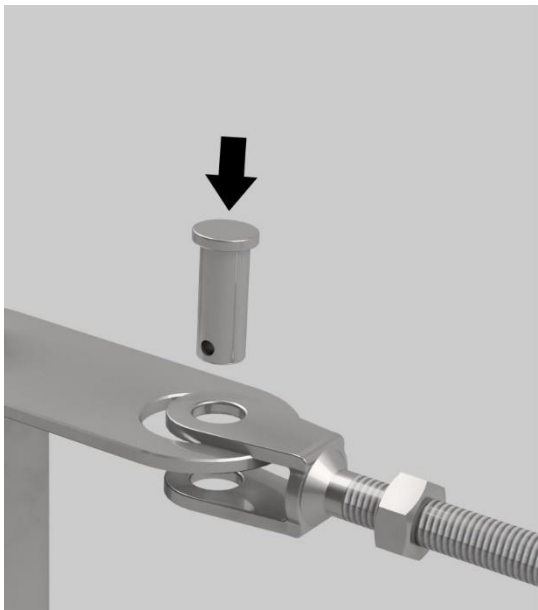
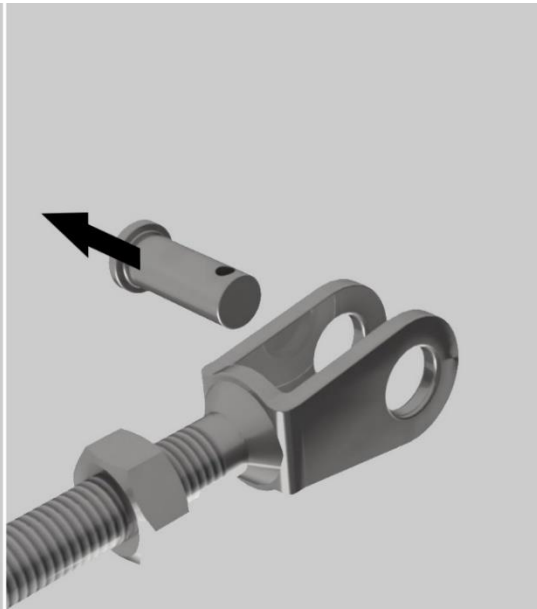
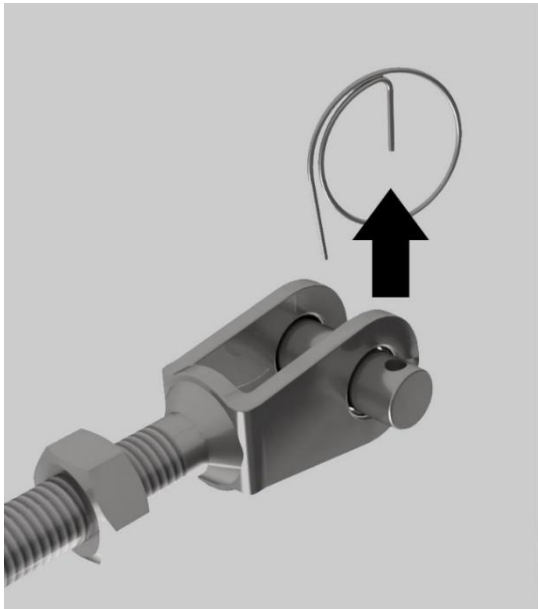

GLIDE SYSTEM | D



GLIDE SYSTEM | D

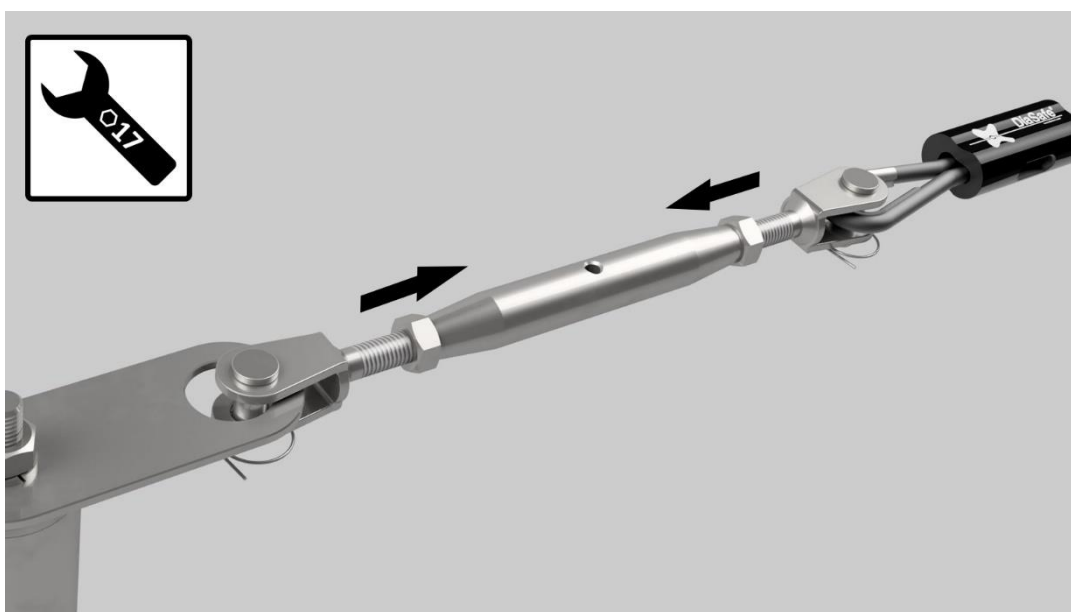
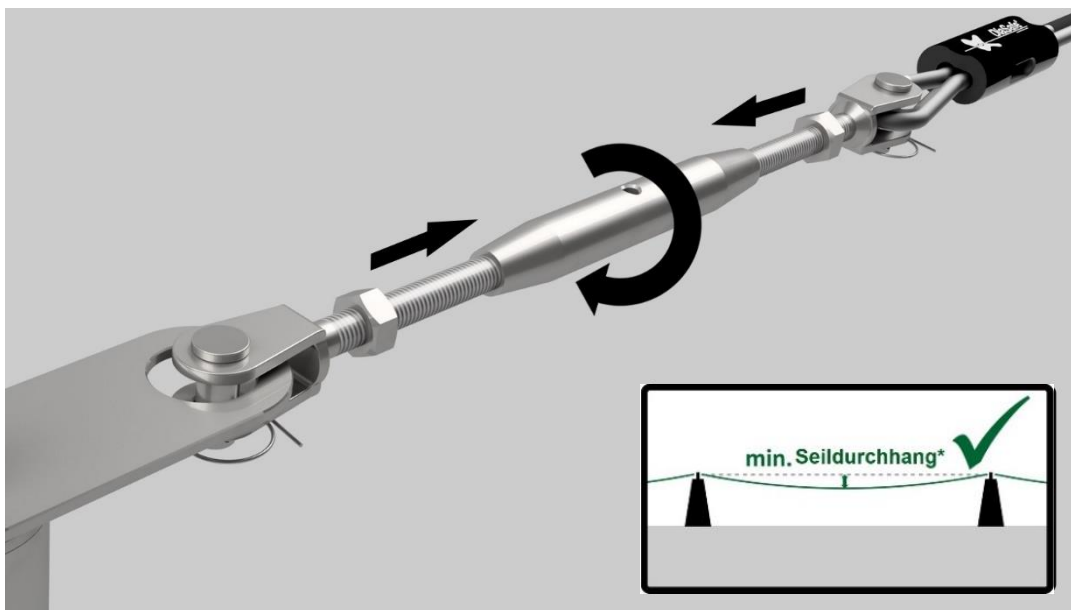
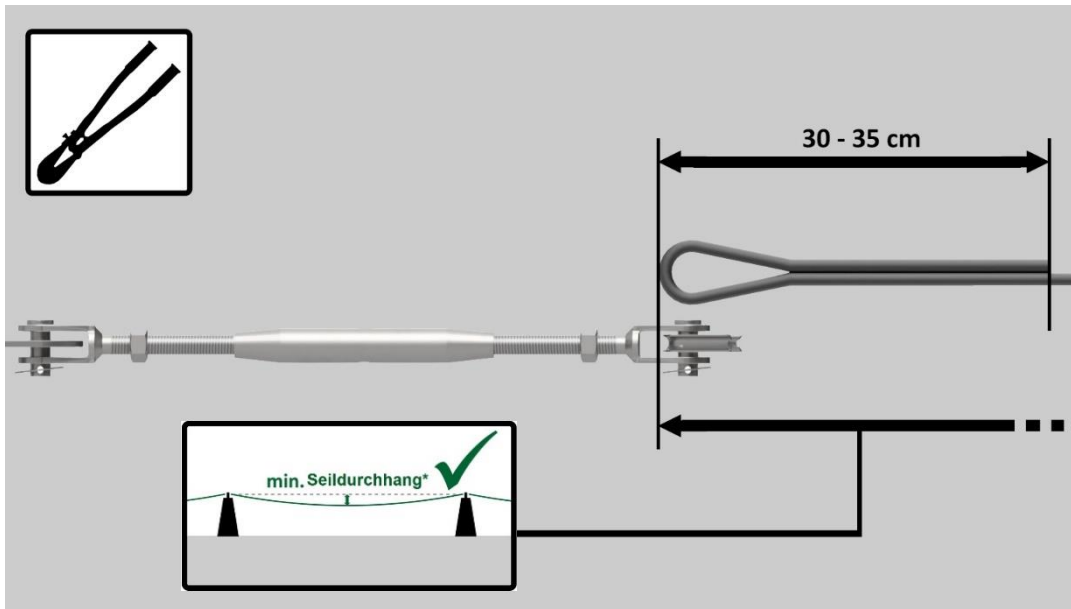

* see page 5 / Siehe Seite 5 / voir page 5 / vedi pagina 5 / Véase la página 5 / lásd 5. oldal

Closed linesystem installation (without start- and end posts) / Montageablauf umlaufendes Seilsystem (ohne Anfangs- und Endstütze) / Installation d'un système fermé (sans Start- et Fin potelet) / Installazione di un sistema chiuso (senza colonna iniziale e terminale) / Proceso de montaje del sistema de cable cerrado (sin soporte de apoyo inicial y final) / Sodronyos zárt rendszer telepítése (kezdő- és végoszlop nélkül)



GLIDE SYSTEM | D

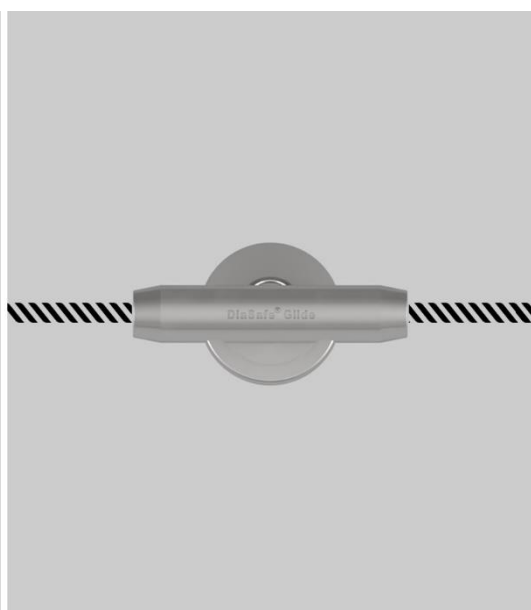
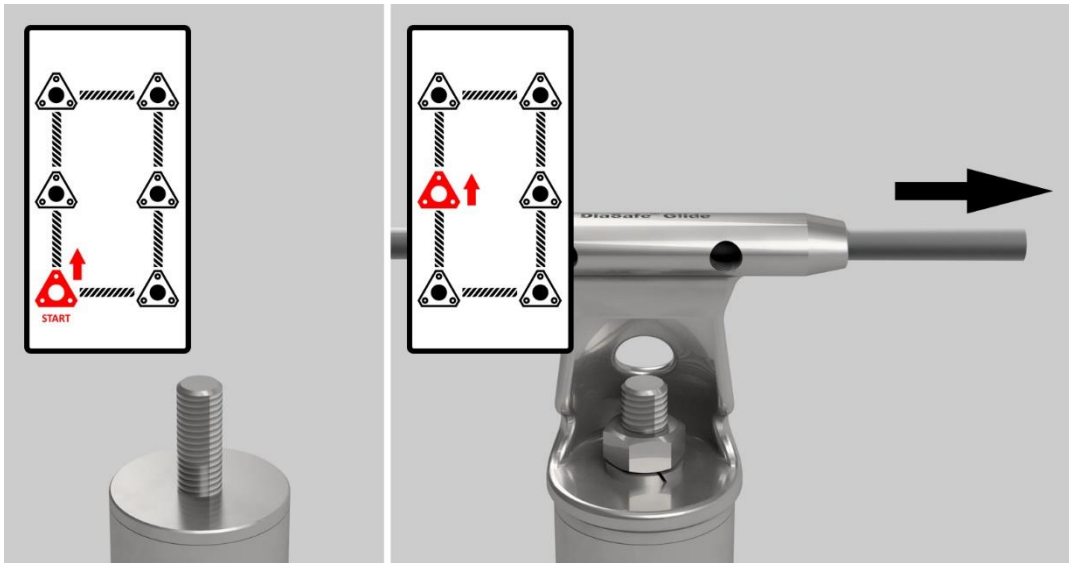



GLIDE SYSTEM | D

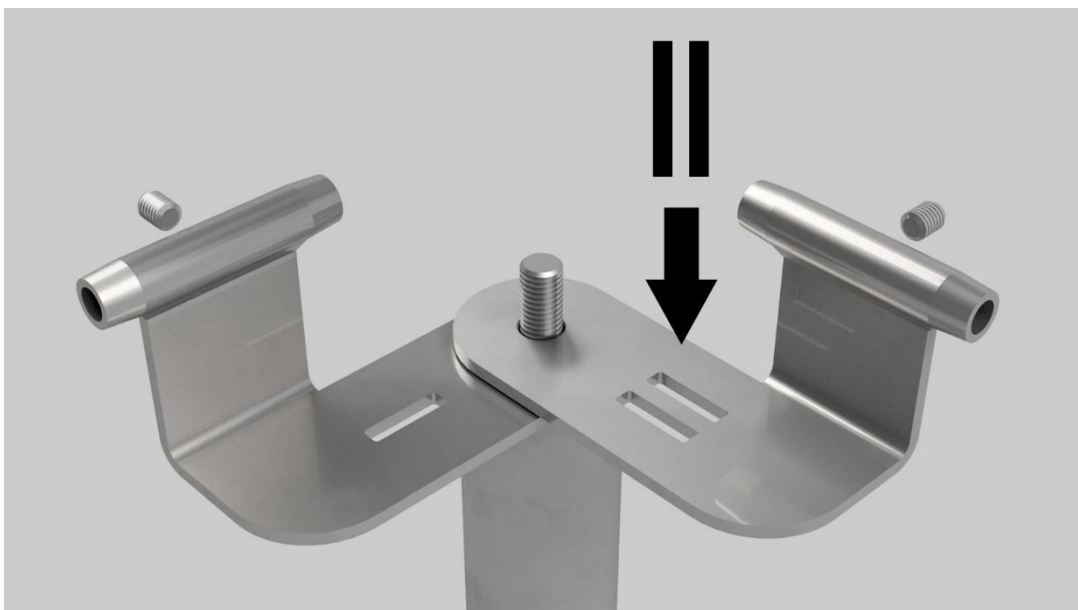
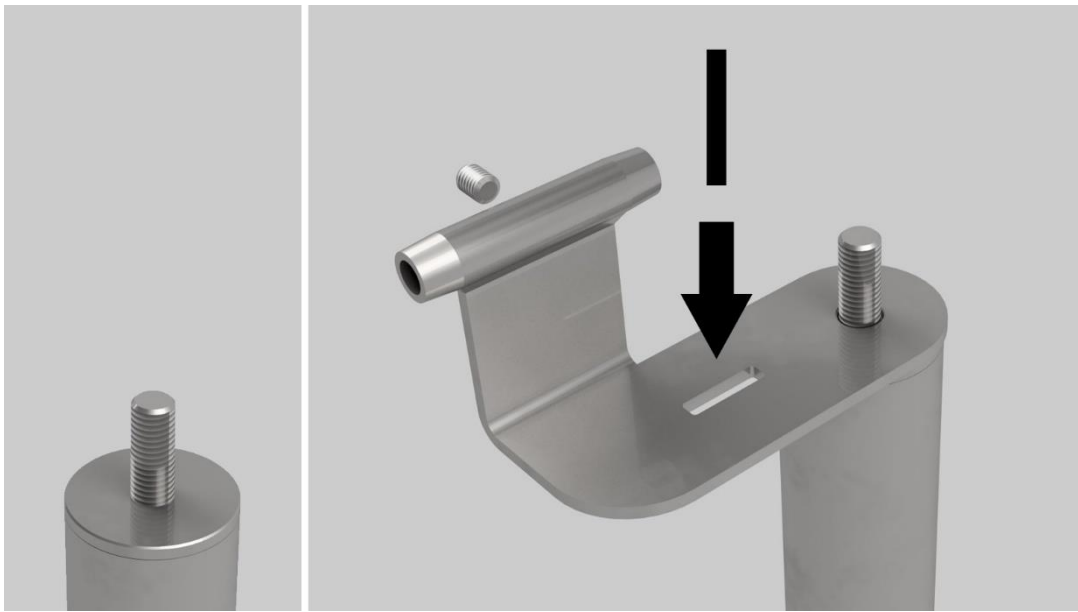
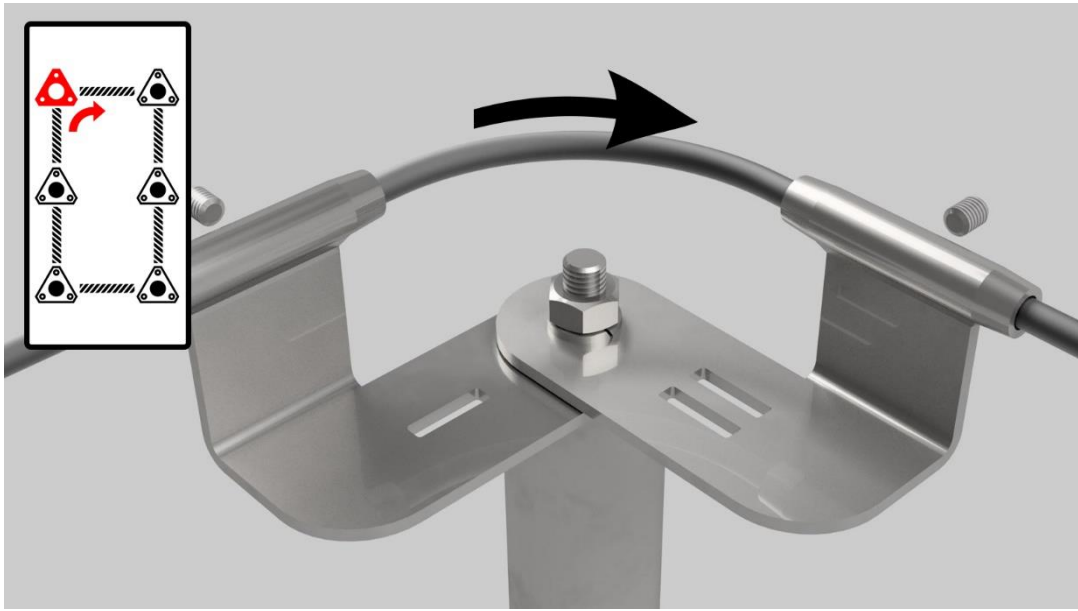

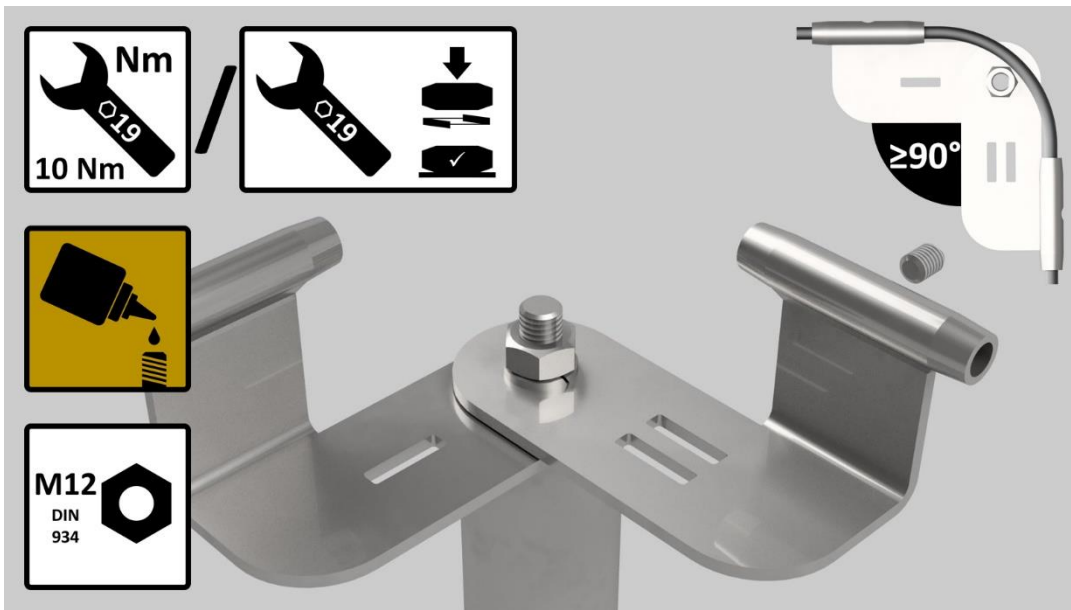

GLIDE SYSTEM | D



GLIDE SYSTEM | D

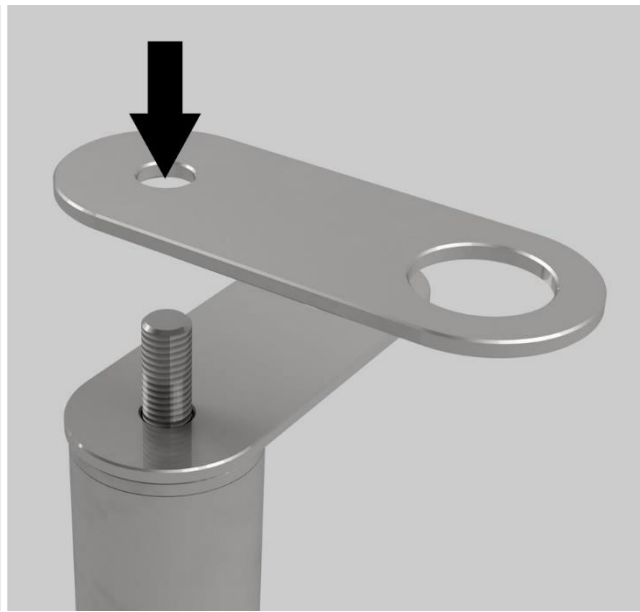
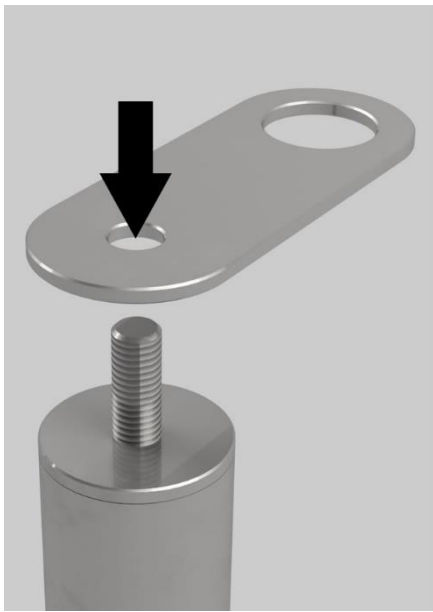
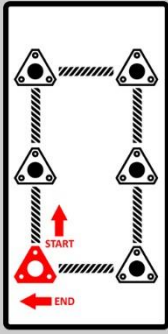

M12
DIN
127 **C**



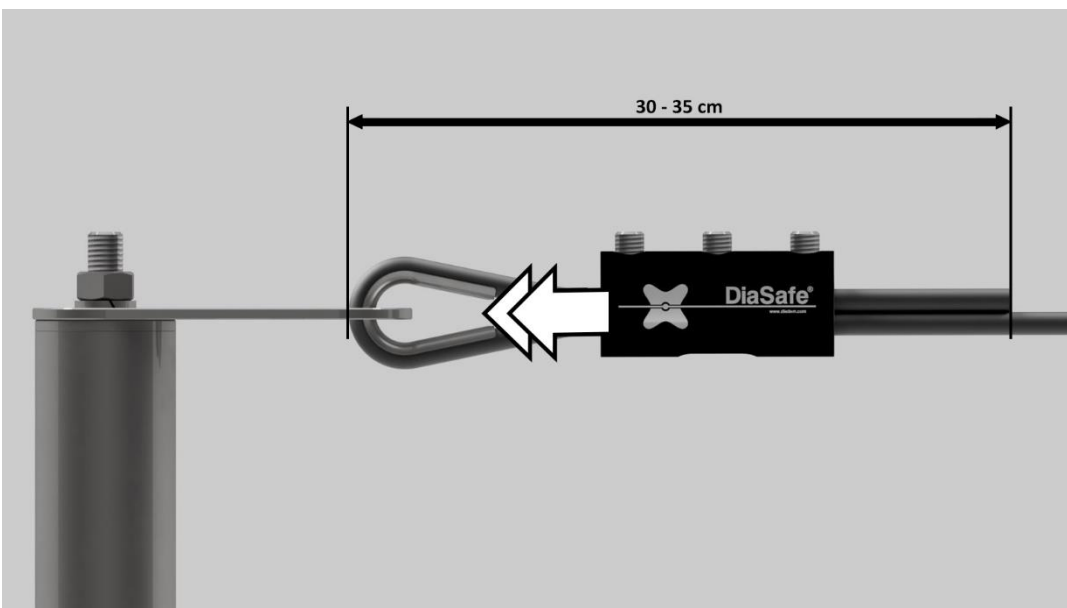
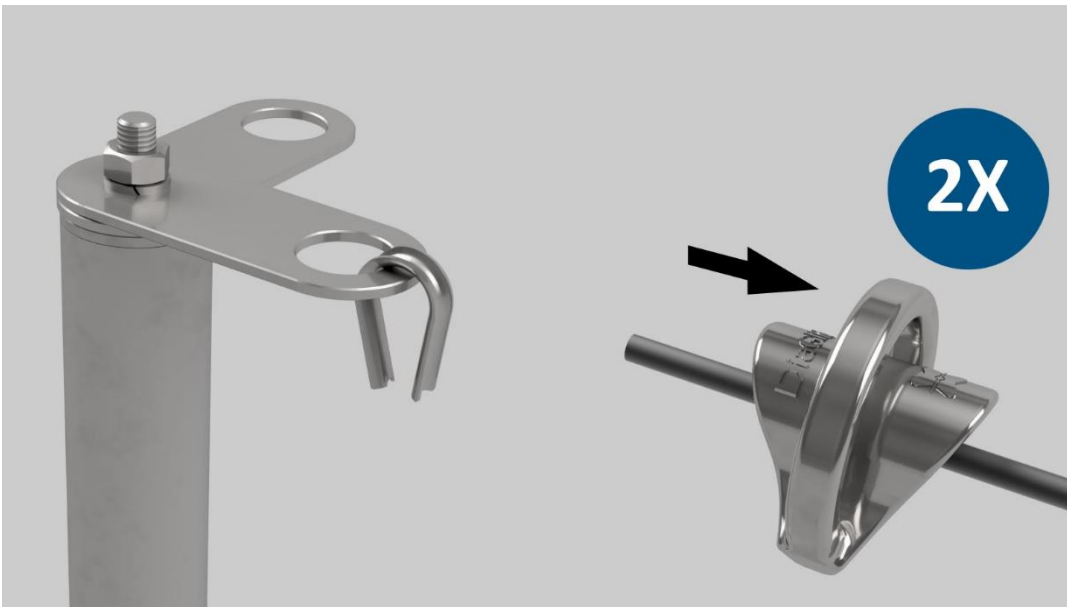



GLIDE SYSTEM | D

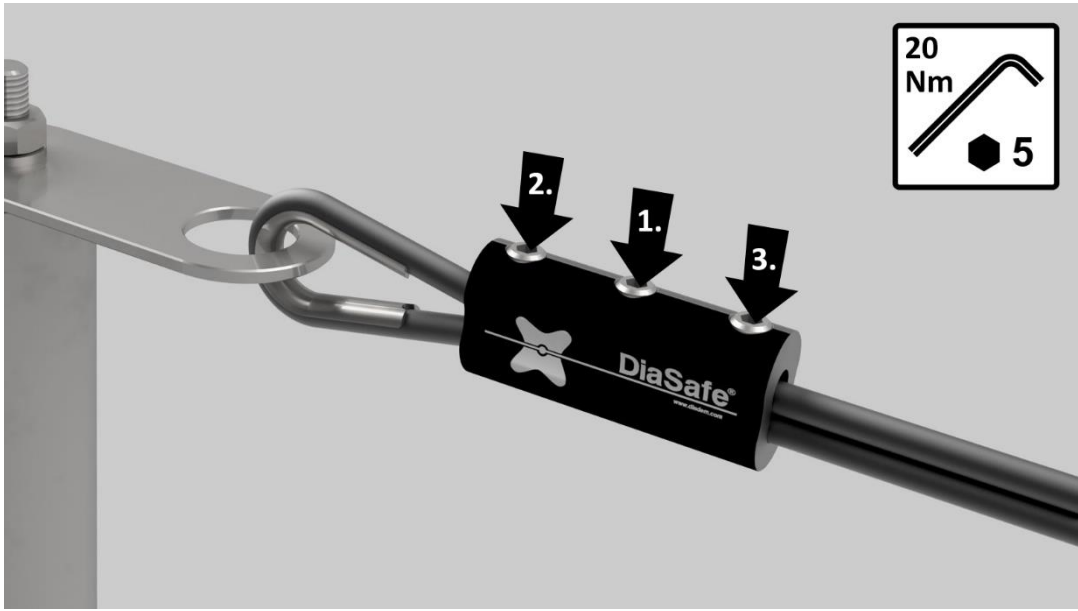

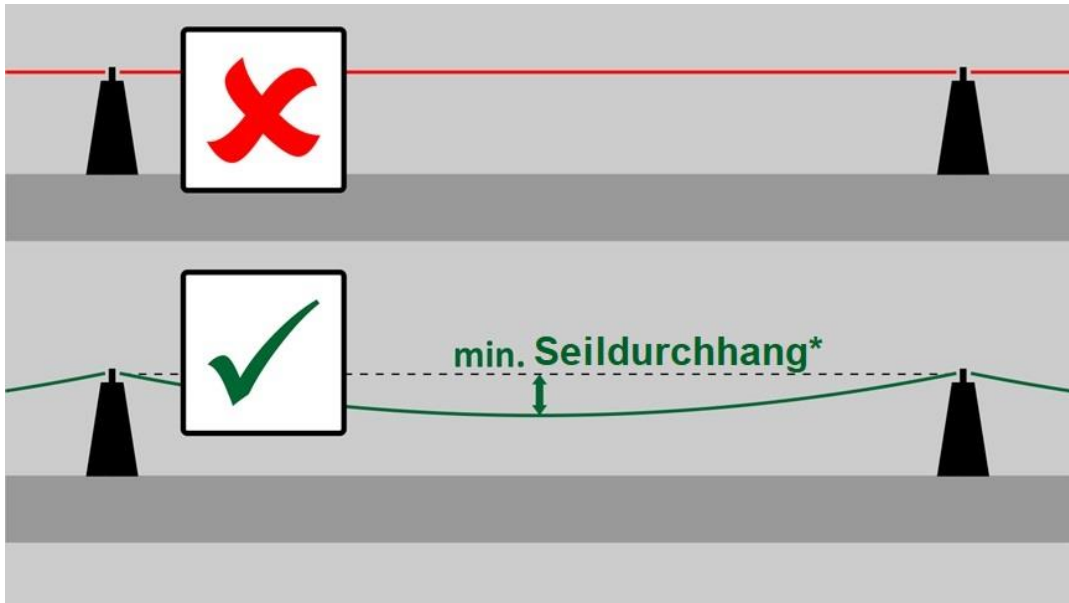

* see page 5 / Siehe Seite 5 / voir page 5 / vedi pagina 5 / Véase la página 5 / lásd 5. oldal



GLIDE SYSTEM | D

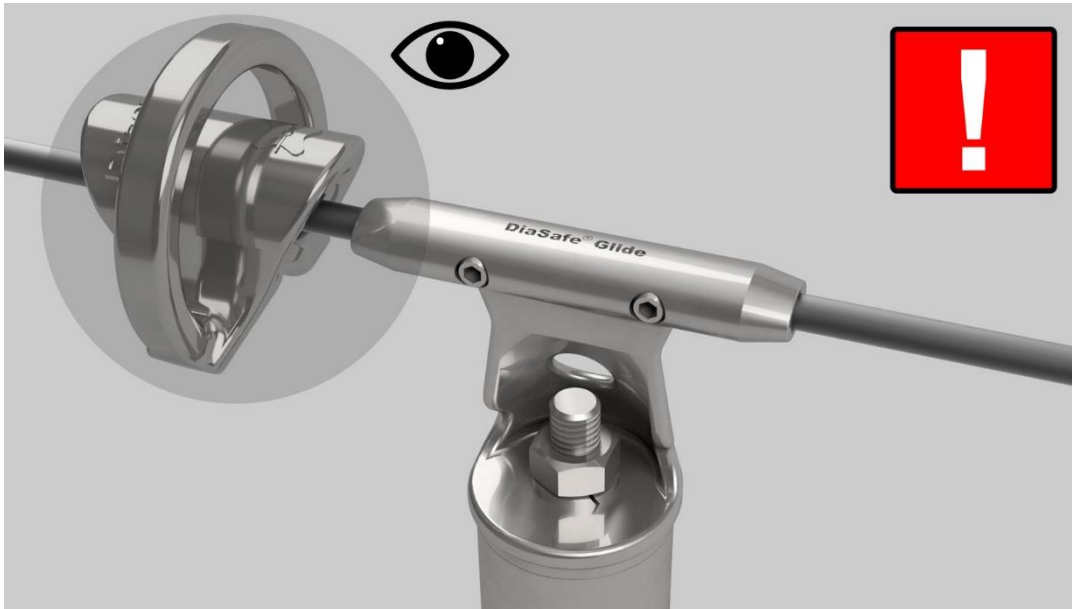

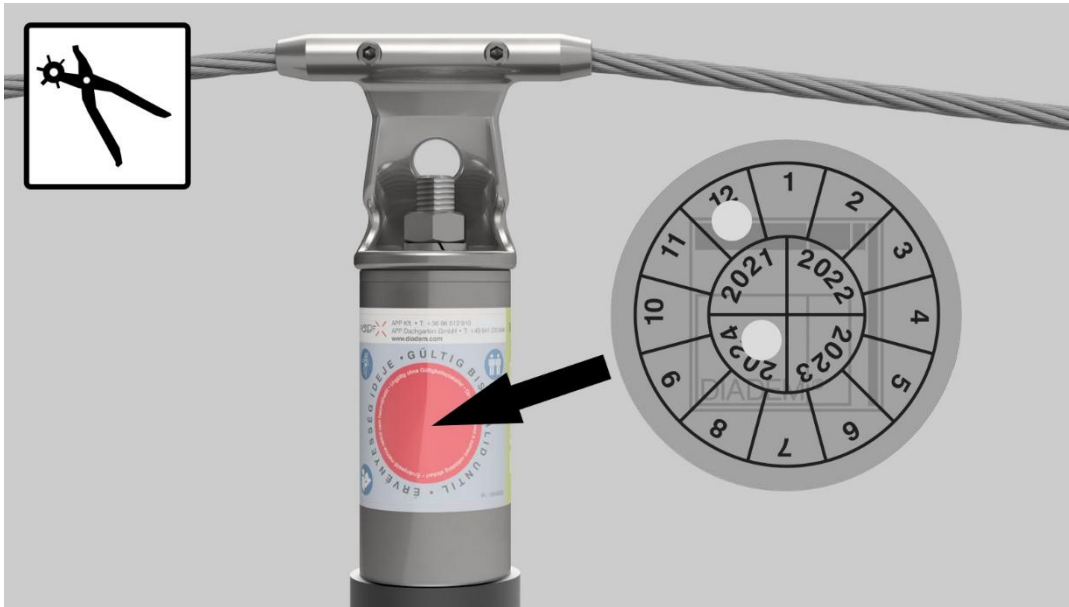

Use according to Technical Manual / Benützung gemäss Gebrauchsanleitung / À utiliser conformément au mode d'emploi / Utilizzo secondo il Manuale Tecnico / Uso de acuerdo con el manual de instrucciones / Műszaki kézikönyv szerinti használat





OPTIONAL

T-connection / T-Verbindung / T-connection / incrocio a T / Conexión en T / „T” elágazás

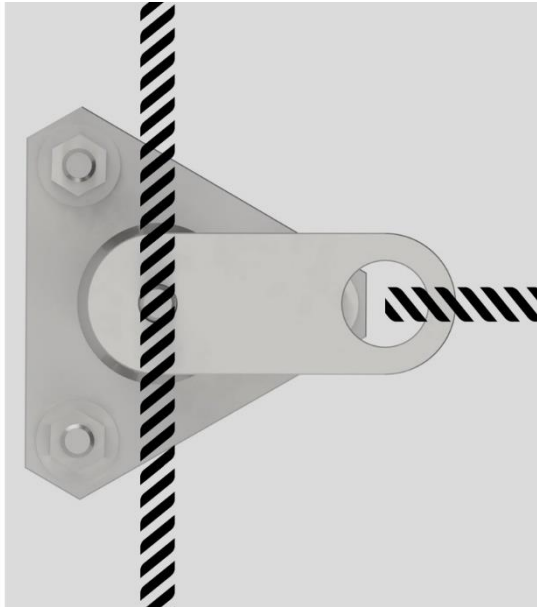
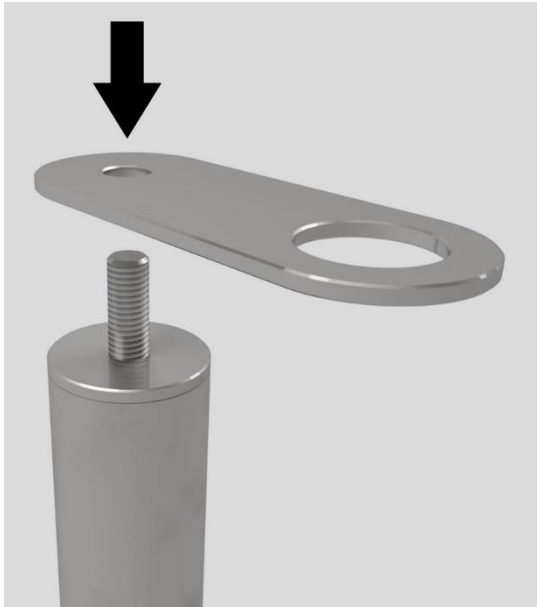
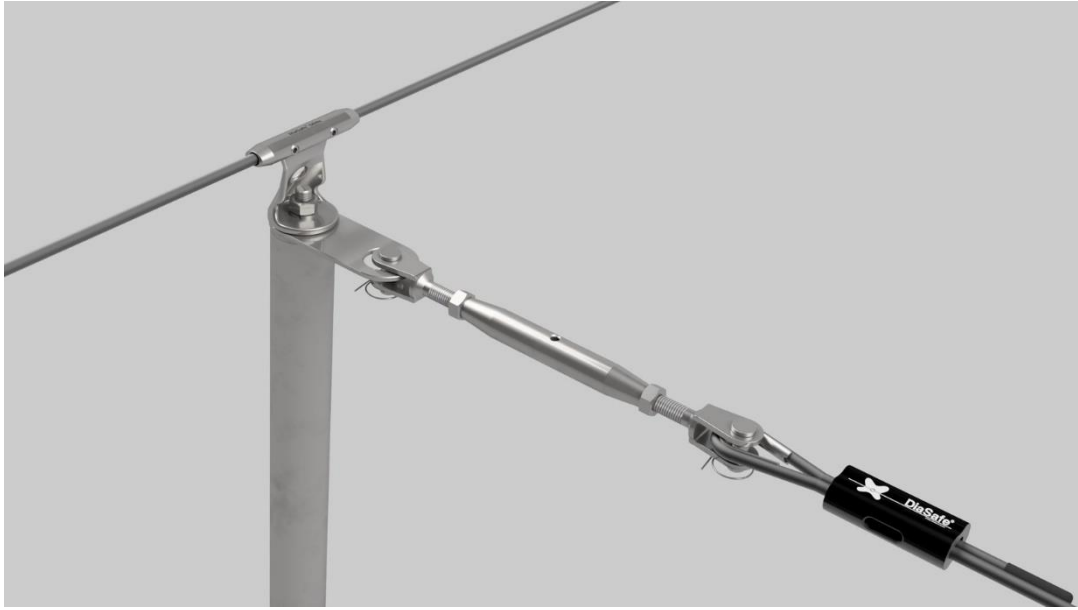

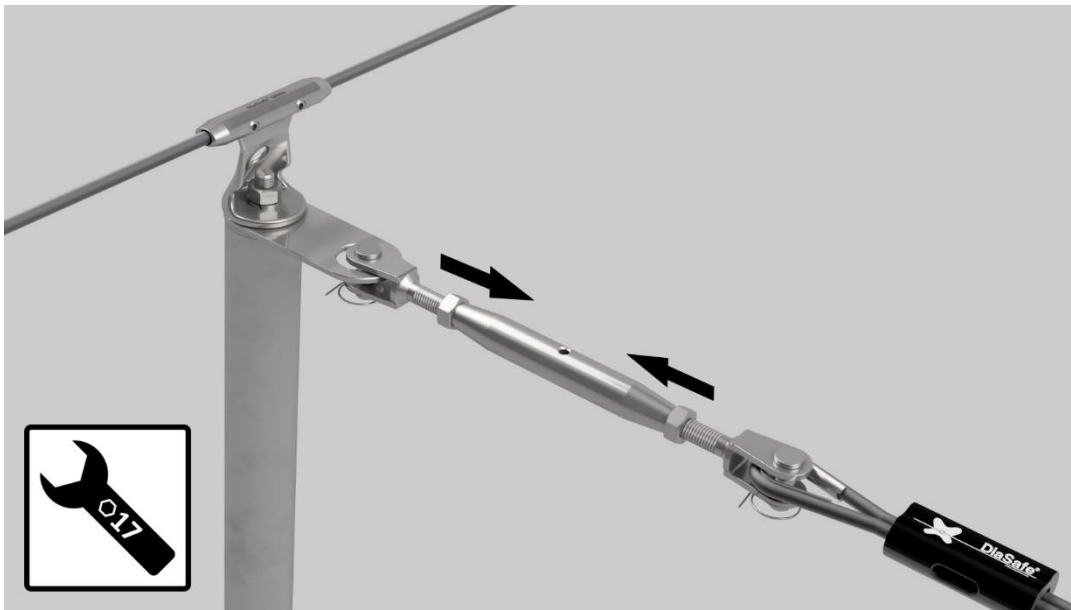
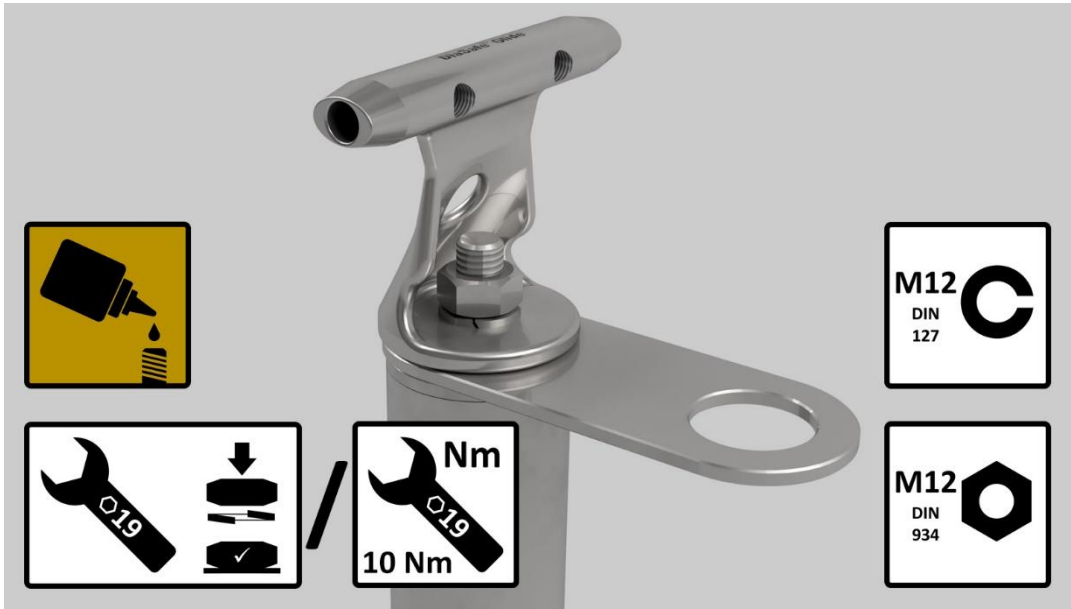



DiaGlider-Fix

DiaGlider-Fix additional installation / DiaGlider-Fix nachträglicher Einbau / Installazione addizionale della navetta DiaGlider-Fix / Installation postérieure du DiaGlider-Fix avec mousqueton / Montaje adicional del carro DiaGlider-Fix / DiaGlider-Fix utólagos beépítése – D1 | D2

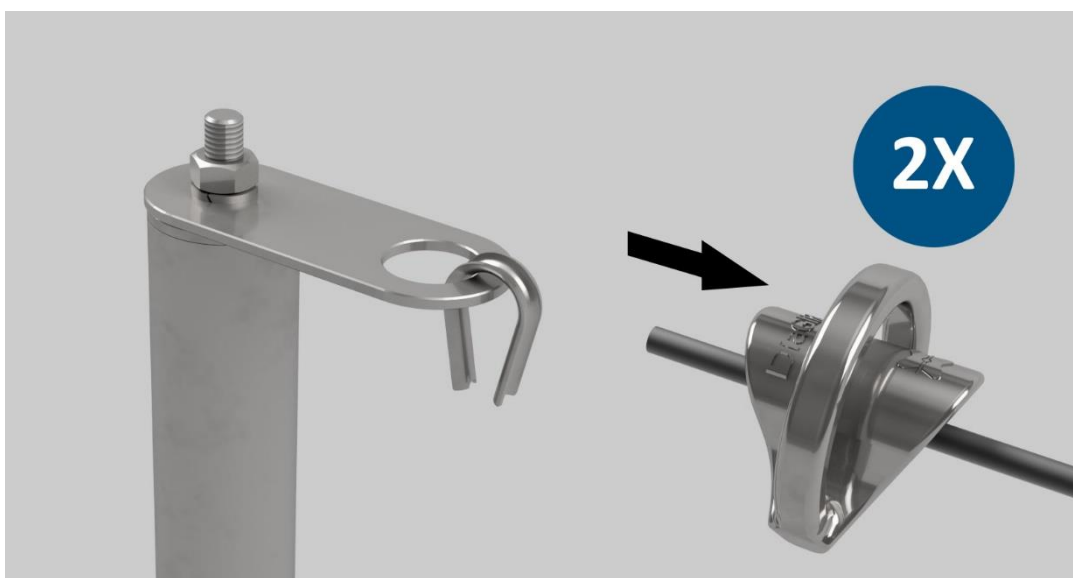
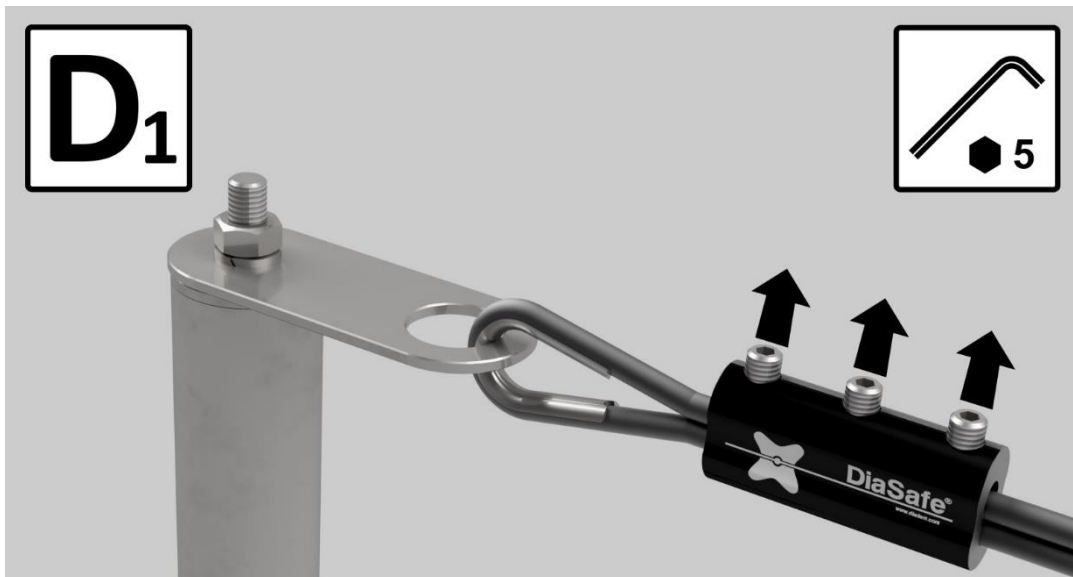
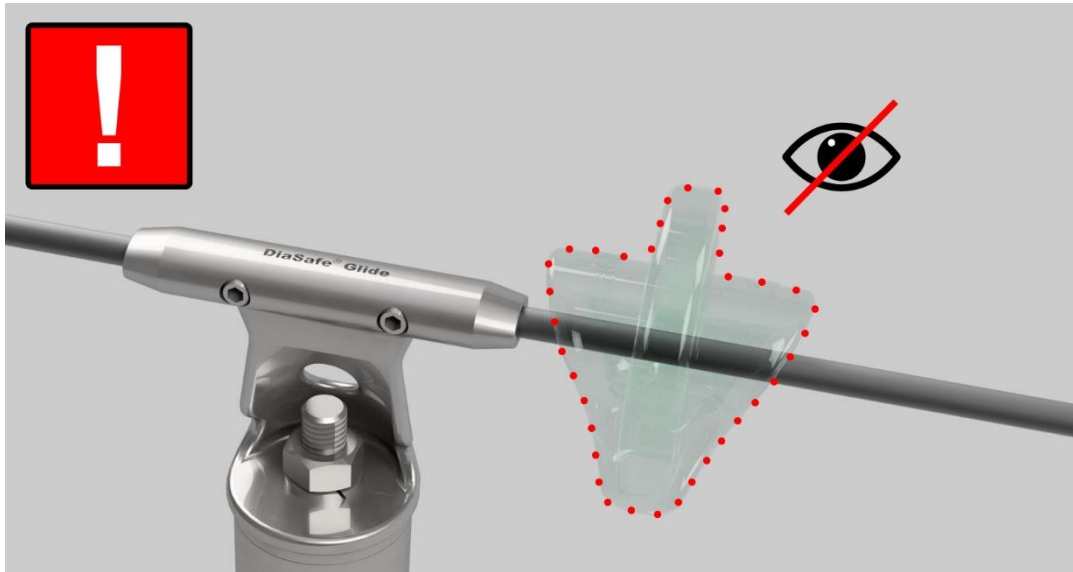

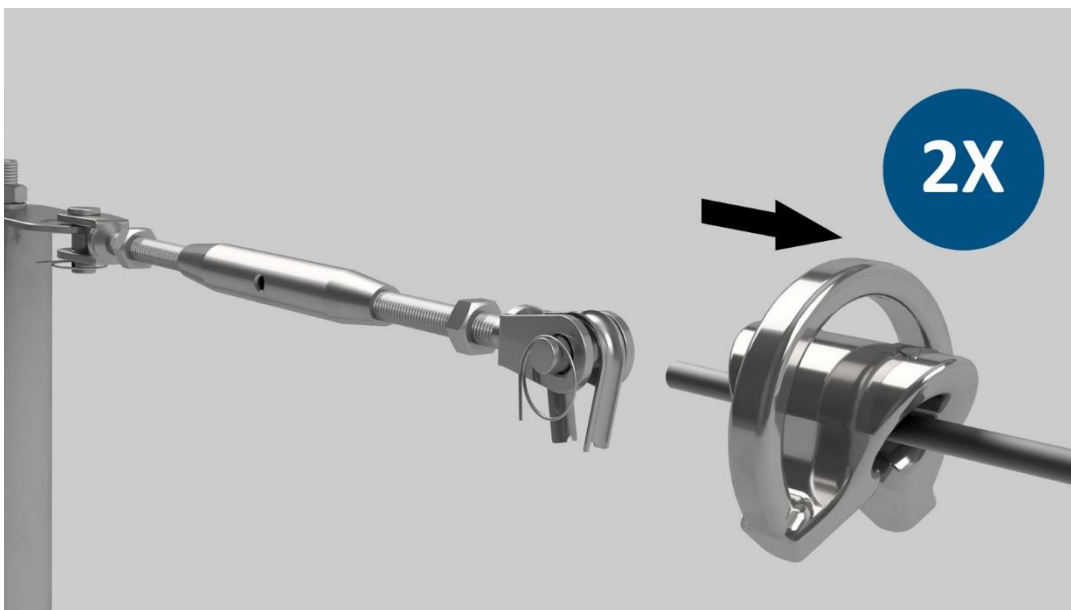
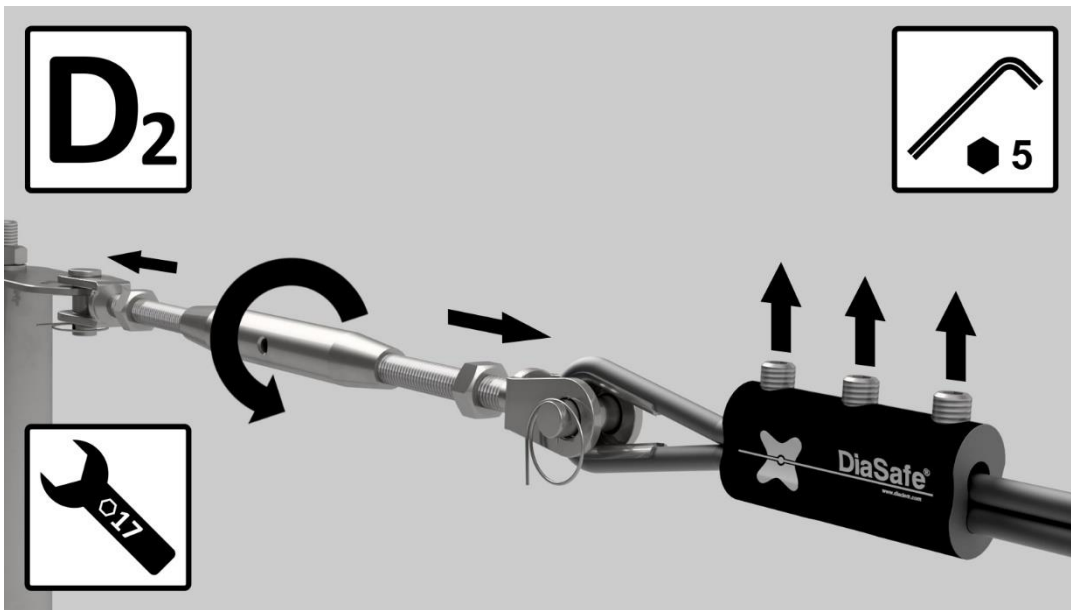
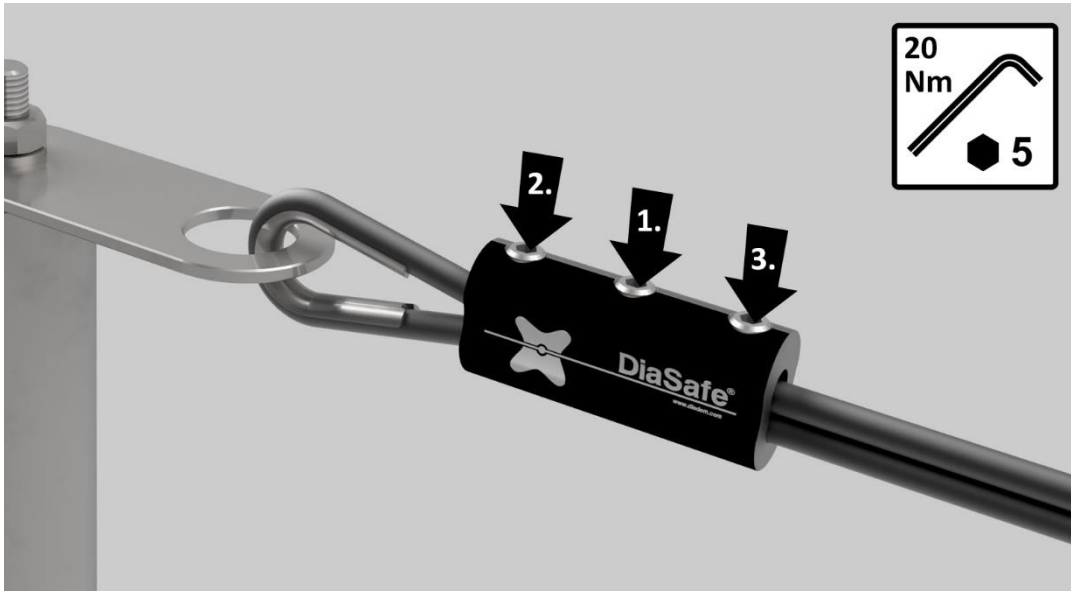

GLIDE SYSTEM | D

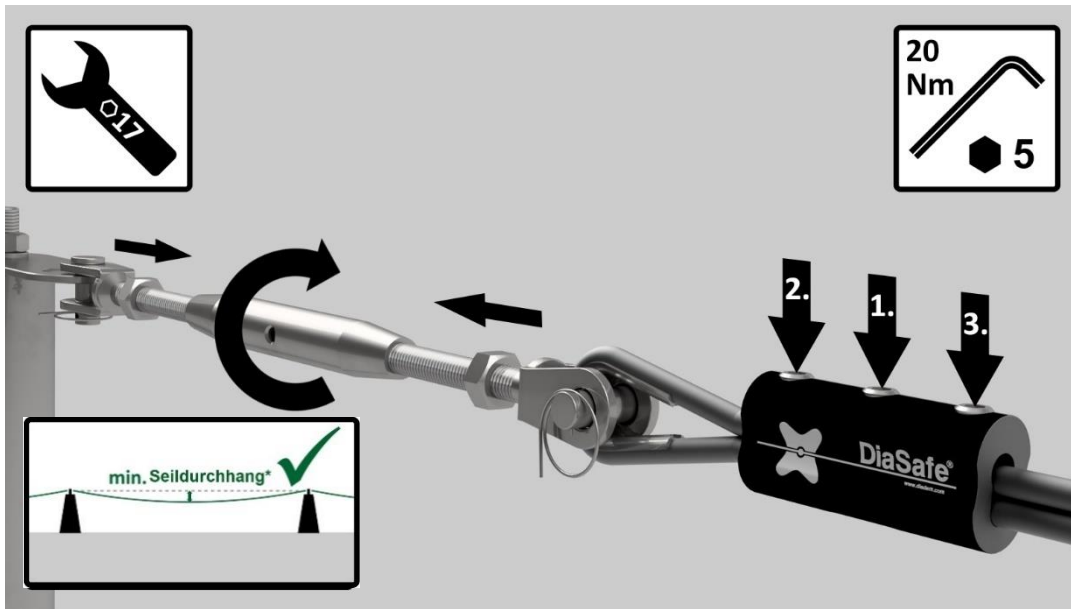

Position of the DiaGlider-Fix out of use / Die Lagerposition des DiaGlider-Fix Durchlaufelementes / Posizione della navetta DiaGlider-Fix quando non è in uso / DiaGlider-Fix avec mousqueton hors d'usage / La posición del carro DiaGlider-Fix cuando no está en uso / DiaGlider-Fix pozíciója használaton kívül

Out of danger zone / Ausserhalb dem Gefahrenbereich / hors de zone de danger / al di fuori della zona del pericolo / Fuera de la zona de peligro / veszélyzónán kívül

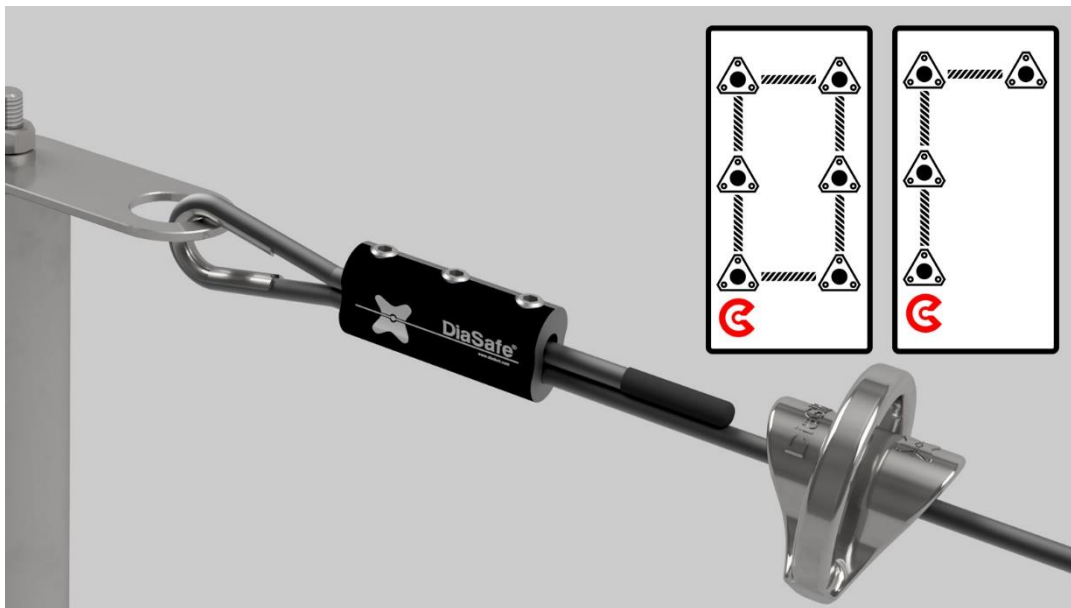

* see page 5 / Siehe Seite 5 / voir page 5 / vedi pagina 5 / Véase la página 5 / lásd 5. oldal

Manufacturer / Hersteller / Fabricant / Produttore / Fabricante / Gyártó:



A.P.P. Kft.
H-9028 Győr
Fehérvári út 75.
T: +36 96 512 910
info@diadem.com
www.diadem.com



APP Dachgarten GmbH
Jurastrasse 21
D-85049 Ingolstadt
T: +49 841 370 9496
info@diadem.com
www.diadem.com

Annexes

Anhänge

Mellékletek

Annex / Anhang / Melléklet 1.

Loop Montageanleitung - Loop installation guide - Loop beépítési útmutató

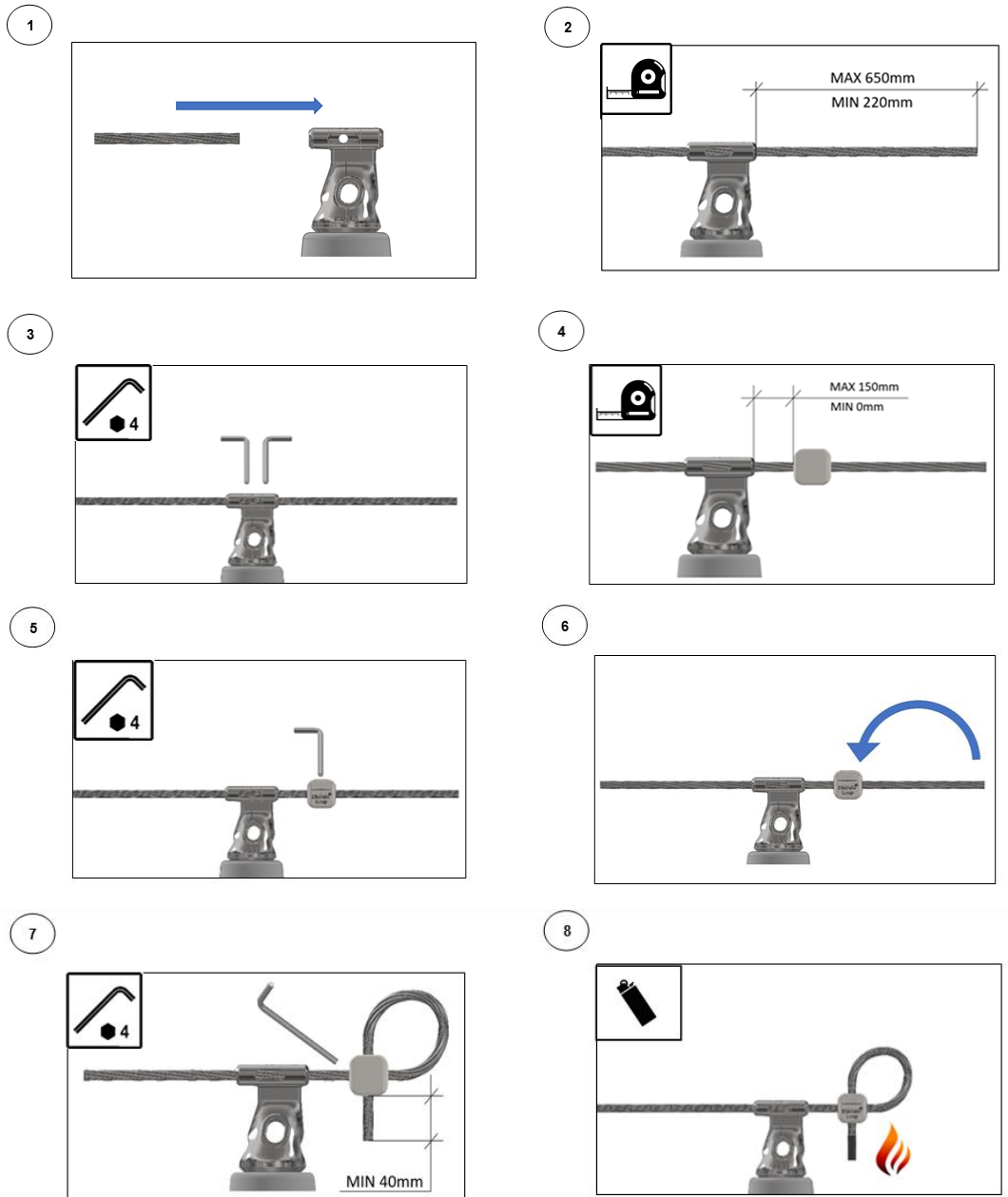

Annex / Anhang / Melléklet 2.

DS 21 Montageanleitung - DS 21 installation guide - DS 21 Beépítési útmutató

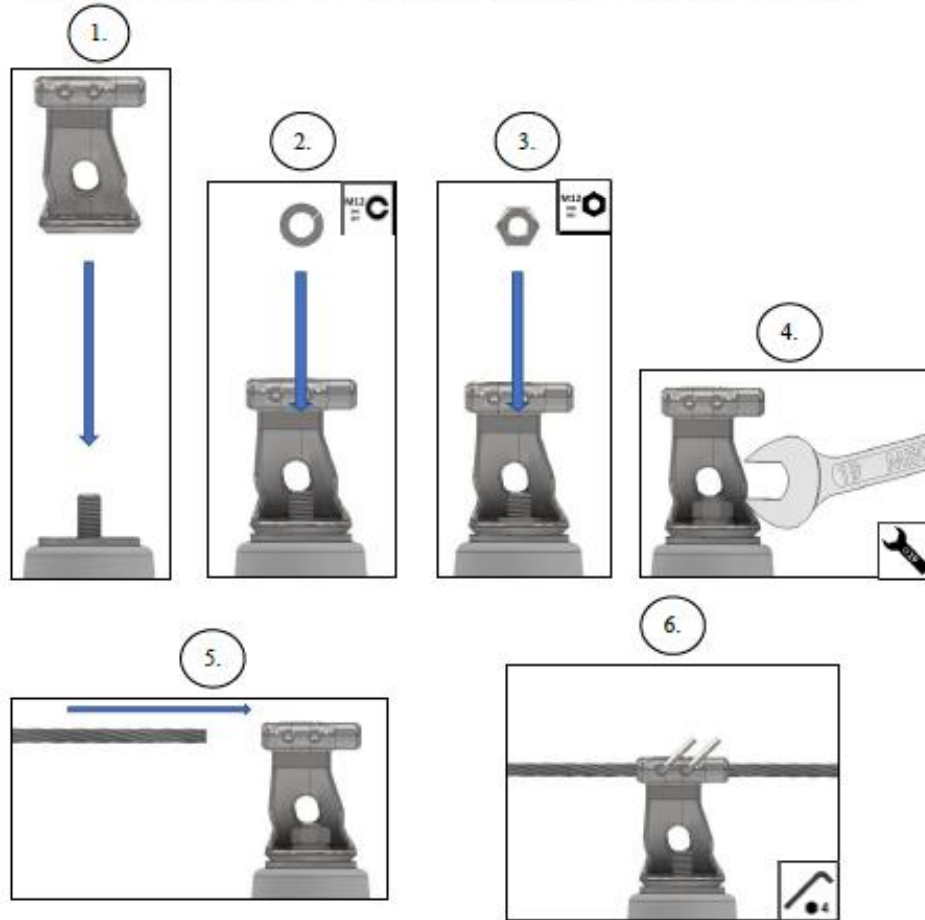

RoofX 2/1 Fastening

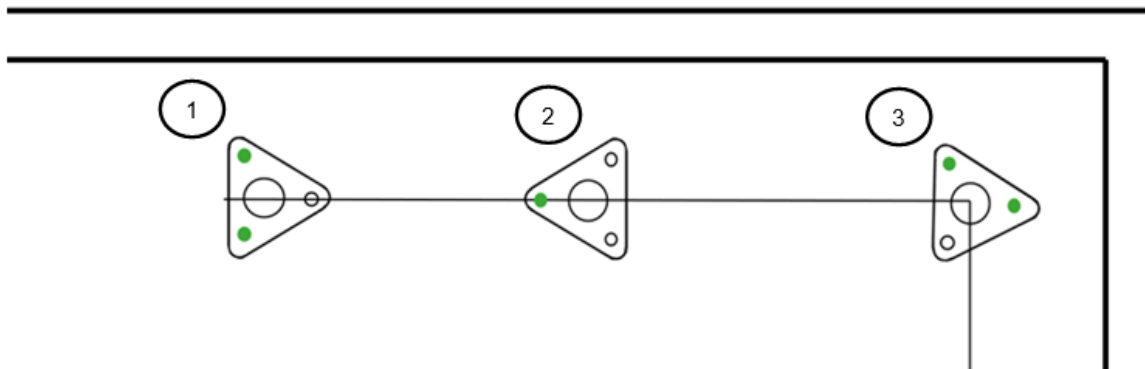

For the corner, start and end posts all require 2 dowels per anchor post.

For the intermediate post requires only 1 anchor.

1. Start and end post

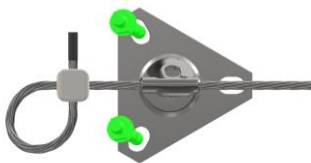

The steel wire rope defined by the dowels of the initial and final support must always run according to the above figure in such a way that the hole of the foot plate remains without a fastener (dowel) is always aligned in the direction of the next intermediate post.

2. Intermediate post

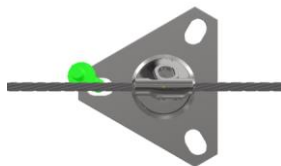

The intermediate posts are fixed so that the dowel and the centre of the posts are in line with the steel wire rope axis.

3. Corner post

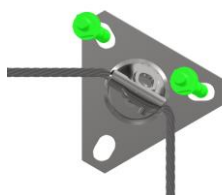

For the corner posts, make sure that the two dowels are attached laterally to the steel wire rope axis in the possible direction of falling.



RoofX 2/1 Befestigung

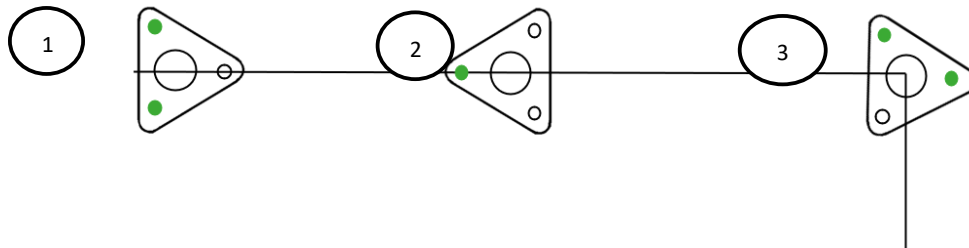

Bei Eck-, Anfangs- und Endpfosten 2 Dübel

Bei Zwischenpfosten 1 Dübel

1. Anfangs- und Endpfosten

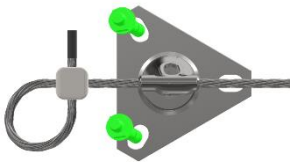

Die durch die Bolzenanker der Anfangs- und Endstütze definierte Seil-Linie muß gemäß obiger Abbildung immer so verlaufen, daß diejenige Bohrung der Fußplatte, die ohne ein Befestigungsmittel (Dübel, Anker, Bolzen) verbleibt, immer in Richtung des nächsten Zwischenpfosten ausgerichtet ist.

2. Zwischenpfosten

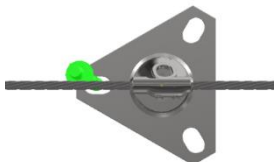

Die Zwischenpfosten werden so befestigt, dass der Bolzenanker und die Mitte der Pfosten in einer Linie mit der Seilachse liegen.

3. Eckpfosten

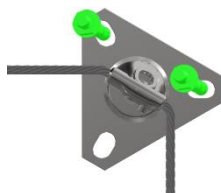

Bei den Eckpfosten ist darauf zu achten, dass die beiden Bolzenanker in der möglichen Fallrichtung seitlich zur Seilachse ausgerichtet sind.

RoofX 2/1 rögzítési opció

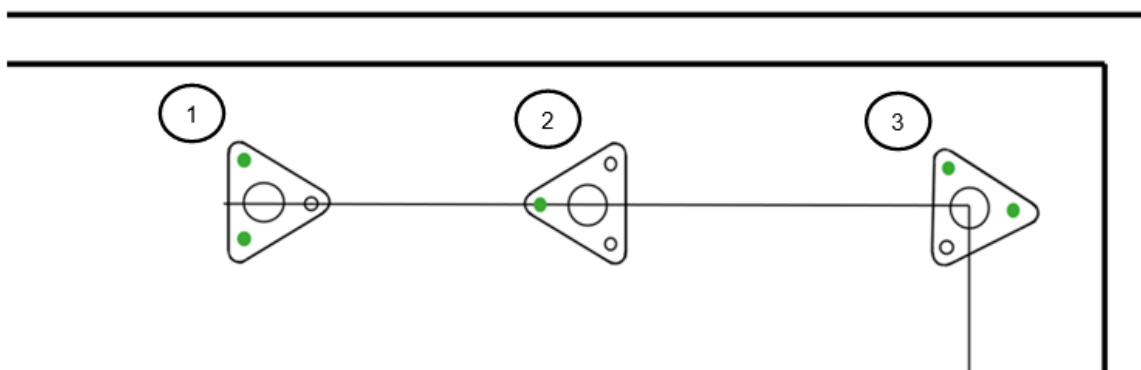

A sarok, a kezdő- és a végoszlopokhoz oszloponként 2 alapcsavarra van szükség.

A köztes oszlophoz csak 1 alapcsavar szükséges.

1. Kezdő- és végoszlop

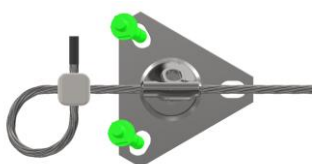

A kezdő- és a végoszlop alapcsavarja által közrefogott sodronynak mindig a fenti ábra szerint kell futnia oly módon, hogy az alapcsavar nélkül maradó talp furata mindig a következő köztesoszlop irányába legyen.

2. Köztesoszlop

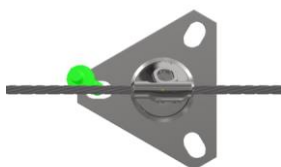

A köztesoszlopokat úgy rögzítjük, hogy az alapcsavar és az oszlop középpontja egy vonalban legyen a sodrony tengelyével.

3. Sarokoszlop

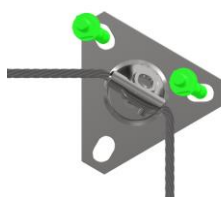

A sarokoszlopoknál ügyelni kell arra, hogy a két alapcsavar a sodrony tengelyéhez oldalirányba, a lehetséges esési irányba legyen rögzítve.