

■ Green Up the Roof!



TECHNICAL MANUAL

RoofX[®]-C, RoofX[®]-W/T, RoofX[®]-EVO, RoofX[®]-ISOFIX Fall Protection Anchoring Systems

Anchor devices as per standards EN 795:2012 and CEN/TS 16415:2013

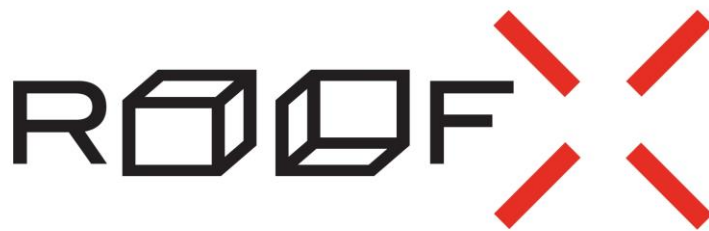

RoofX[®]-C Single / Glide
RoofX[®]-W/T Single / Glide
RoofX[®]-EVO Single / Glide
RoofX[®]-ISOFIX Single / Glide

Table of contents

1	Description of symbols	3
2	Introduction – General description	4
2.1	Single anchor device	4
2.1.1	RoofX®-C Single	4
2.1.2	RoofX®-W/T Single	4
2.1.3	RoofX®-EVO Single	4
2.1.4	RoofX®-ISOFIX Single	4
2.2	Glide Line system	5
2.2.1	RoofX®-C Glide	5
2.2.2	RoofX®-W/T Glide	5
2.2.3	RoofX®-EVO Glide	5
2.2.4	RoofX®-ISOFIX Glide	5
2.2.5	Combination options	5
2.2.6	Temporary rope system	6
3	Safety instructions	7
3.1	General safety instructions	7
3.2	Application	8
4	Manufacturer's responsibility, warranty	10
4.1	General terms of warranty	10
4.2	Expected lifetime	11
5	System design, and components	12
5.1	RoofX® Single anchoring points	12
5.1.1	RoofX®-C Single	12
5.1.2	RoofX®-W/T Single	12
5.1.3	RoofX®-EVO Single	13
5.1.4	RoofX®-ISOFIX Single	13
5.1.5	RoofX® Single / Anchor point components	14
5.2	RoofX® Glide Line system	14
5.2.1	RoofX®-C Glide	14
5.2.2	RoofX®-W/T Glide	14
5.2.3	RoofX®-EVO Glide	15
5.2.4	RoofX®-ISOFIX Glide	15
5.2.5	RoofX® Glide / Line system components:	16
5.2.6	RoofX® Glide / Line system optional components:	16
5.3	Fastening elements, accessories	17
5.3.1	RoofX®-C fastening elements (concrete)	17
5.3.2	RoofX®-W/T fastening elements (wood)	17
5.3.3	RoofX®-W/T fastening elements, trapezoidal sheet	17
5.3.4	Insulating collar	17
5.3.5	Recommended karabiner to connect our systems	17
6	Load bearing structure	18
6.1	Anchor height and roof layer build-up	18
6.2	Mounting on the load bearing structure	18
6.2.1	RoofX®-C, RoofX® EVO és ISOFIX	18
6.2.2	RoofX®-W/T applied to wood	18
6.2.3	RoofX®-W/T applied to trapezoidal sheet	19
6.2.4	Special case for fastening with 2 or 1 anchor (RoofX®-C)	19
7	Information on system installation and usage	19
8	System installation and annual inspection information	20
8.1	System installation and annual inspection	20
8.2	Information regarding required free fall height	20
9	Documentation	20
10	Technical data	21
11	Disposal	21
12	Manufacturer, certification	21

1 Description of symbols

Pictograms in the Technical Manual have the following meanings:



System users are obliged to carefully read this manual and the related **service book**, and shall closely follow all relevant safety regulations and user requirements listed herein.

By their signature, they shall declare that they have understood the contents. The safety regulations and installation instructions must be strictly observed. In case of any ambiguities or questions, please contact the supplier or the manufacturer



Types of application of the fall arrest system based on the number of simultaneous users: (in the standard case: 1+1 persons).

In case of 1+1 persons use (2 persons includes a first-aid in the case of rescue) the system can be used by 2 persons at the same time. But the fall arrest system provides only the required safety, provided a fall of both persons does not occur simultaneously.



The number of people who can simultaneously use the fall protection system is 3 persons.



The use of personal protective equipment against falls from a height (PPE in accordance with EN 361 and EN 363) is required. The manufacturer's specifications for the use of personal protective equipment against falls from a height must be strictly observed.



Danger, which could lead to severe injury or death.

2 Introduction – General description

2.1 Single anchor device

2.1.1 RoofX®-C Single

RoofX®-C Single was developed as a permanent anchor device for the personal fall prevention for max. **1 + 1 persons** at a time in accordance with standards **EN 795:2012 (Type A)** and **CEN/TS 16415:2013. Max. 10° roof incline** fixed on reinforced concrete structure.

The anchoring point is suitable for use as the following fall prevention systems as per EN 363:2018:

- Fall arrest system
- Restraint system

2.1.2 RoofX®-W/T Single

RoofX®-W/T Single was developed as an anchor point for the personal fall prevention for max. **1 + 1 persons** at a time in accordance with standards **EN 795:2012 (Type A)** and **CEN/TS 16415:2013. Max. 10° roof incline** fixed on OSB, Wood, trapezoidal sheet structure.

Marking: **W**: wood; **T**: trapezoidal sheet.

The anchoring point is suitable for use as the following fall prevention systems as per EN 363:2018:

- Fall arrest system
- Restraint system

2.1.3 RoofX®-EVO Single

RoofX®-EVO Single was developed as a permanent anchor device for the personal fall prevention for max. **3 persons** at a time in accordance with standards **EN 795:2012 (Type A)** and **CEN/TS 16415:2013. Max. 10° roof incline** fixed on reinforced concrete structure.

The anchoring point is suitable for use as the following fall prevention systems as per EN 363:2018:

- Fall arrest system
- Restraint system

2.1.4 RoofX®-ISOFIX Single

RoofX®-ISOFIX Single was developed as a permanent anchor device for the personal fall prevention for max. **3 persons** at a time in accordance with standards **EN 795:2012 (Type A)** and **CEN/TS 16415:2013. Max. 10° roof incline** fixed on reinforced concrete structure.

The anchoring point is suitable for use as the following fall prevention systems as per EN 363:2018:

- Fall arrest system
- Restraint system

2.2 Glide Line system

2.2.1 RoofX®-C Glide

RoofX®-C Glide was developed as horizontal line system with traveller for the personal fall prevention for max. **1 + 1 persons** at a time in accordance with standards **EN 795:2012 (Type C)** and **CEN/TS 16415:2013. Max. 10° roof incline** fixed on reinforced concrete structure.

The anchoring point is suitable for use as the following fall prevention systems as per EN 363:2018:

- Fall arrest system
- Restraint system

2.2.2 RoofX®-W/T Glide

RoofX®-W/T Glide was developed as horizontal line system with traveller for the personal fall prevention for max. **1 + 1 persons** at a time in accordance with standards **EN 795:2012 (Type C)** and **CEN/TS 16415:2013. Max. 10° roof incline** fixed on OSB, Wood, trapezoidal sheet structure.

Marking: **W**: wood; **T**: trapezoidal sheet.

The anchoring point is suitable for use as the following fall prevention systems as per EN 363:2018:

- Fall arrest system
- Restraint system

2.2.3 RoofX®-EVO Glide

RoofX®-EVO Glide was developed as horizontal line system with traveller for the personal fall prevention for max. **3 persons** at a time in accordance with standards **EN 795:2012 (Type C)** and **CEN/TS 16415:2013. Max. 10° roof incline** fixed on reinforced concrete structure.

The anchoring point is suitable for use as the following fall prevention systems as per EN 363:2018:

- Fall arrest system
- Restraint system

2.2.4 RoofX®-ISOFIX Glide

RoofX®-ISOFIX Glide was developed as horizontal line system with traveller for the personal fall prevention for max. **3 persons** at a time in accordance with standards **EN 795:2012 (Type C)** and **CEN/TS 16415:2013. Max. 10° roof incline** fixed on reinforced concrete structure.

The anchoring point is suitable for use as the following fall prevention systems as per EN 363:2018:

- Fall arrest system
- Restraint system

2.2.5 Combination options

All types of **RoofX® Glide** and **DiaSafe® Line** safety systems (**RoofX®-C Glide, RoofX®-W/T Glide, RoofX® -EVO Glide, RoofX® -ISOFIX Glide, DiaSafe® Line, DiaSafe® Line Multi, Wall-Fix® Line Multi, Wall-Fix® Glide**) can be combined with each other, making a coherent cable system mounted on different surfaces. In such cases the system functions and the number of permitted users shall be adjusted according to the least favourable conditions.

The high standards of the RoofX® fall protection anchoring systems are guaranteed by the manufacturer's quality management system which conforms to standards ISO 9001:2015 and ISO 14001:2015 and indicate the highest quality in production, from the initial selection of components through to the final quality control.



2.2.6 Temporary rope system

Our securing systems can also be used as a temporary system. It can be used during construction work as long as the wire rope is not yet installed on the system and only in accordance with the manufacturer's installation instructions! The temporary bracing can only be used as a fall protection during short-term work.

The temporary rope can be used with any "head" to which the rope carabiner can be attached (e.g. DS Line Pro Head Kit, Seat Head Kit, etc.).

2.2.6.1 General notes

- This equipment may only be used under the specified operating conditions and for the intended purpose.
- The free ends of a two section lanyard should not be fastened on a harness belt.
- Care must be taken to ensure that the complete fall arrest system is assembled correctly, as incorrect combination of components may impair safe operation.
- Do not allow contact with acids, oils and corrosive chemicals (liquids or vapors); however, if this is unavoidable, rinse the fall arrest harness immediately after use and have it checked by a specialist!
- Protect textile materials from temperatures above 60°C. Care must be taken to avoid melting on the harnesses. Melting includes traces of sweat drops.
- Avoid any risk of corrosion and excessive heat or cold!
- Marking the equipment with solvent-based marking felt (Text Maker / Edding) on the harness strap or rope is prohibited, as this may damage the textile fabric.
- The manufacturer's documentation (Instructions for Use Part 1, Instructions for Use Part 2 and the test book) must be kept near the equipment.

2.2.6.2 Cleaning

After finishing work, the entire unit must be cleaned of all dirt. Cleaning must be carried out with warm water at a maximum temperature of 30° C and a mild cleaning agent (do not use thinner or similar agents).

The device must then be allowed to air dry and protected from direct exposure to heat (e.g. fire or other heat sources). However, care must be taken to ensure that the "gripping surfaces" (friction surfaces between the metal elements and the ropes) do not come into contact with oil.

2.2.6.3 Storage

Storage and transportation should be in a dry and dust-free condition in a closed metal or plastic box or PVC bag. Store in a well-ventilated place and away from direct sunlight.

To ensure a long service life, the PPE should not be exposed to strong sunlight or rain for longer than necessary.

2.2.6.4 Inspection

PPE used to prevent falls should be inspected by a specialist or by the manufacturer as required, but at least every twelve months. The manufacturer's instructions must be followed!

PPE must be visually inspected before each use!

The safety of the user depends on the functionality and durability of all equipment. In addition, the user should check the functions of the equipment and pay special attention to the following points:

- a functional check of the karabiner used;

- checking the function of fall protection devices or connecting devices used at the same time;
- inspection of end connections (seams, rope releases, knots);
- inspection of harnesses, harness parts, plastic parts and ropes for damage (e.g. deformations, cuts, cracks, thermal effects, welds or abrasion);
- the legibility of the product marking shall be checked.

2.2.6.5 Service life

Proper care and storage will increase the life of the device and thus ensure optimum safety.

The maximum service life of a temporary guying device depends on its condition and is expected to be 8.5 years.

3 Safety instructions

3.1 General safety instructions

- The installer is solely responsible for the professional installation of our fall protection systems. The system is to be installed and used in accordance with these instructions for use and assembly. The fitter should therefore be familiar with our system, e.g. through appropriate training, which we recommend.
- The user of the fall protection system must be familiar with and comply fully with local, safety and health and safety regulations.
- The system may only be used by people who:
 - are trained in the use of PPE (Personal Protective Equipment).
 - are physically and psychologically fit (health restrictions such as heart and circulatory problems, medication, alcohol consumption, etc. reduce user safety).
 - understood and accepted the possibilities, restrictions and risks of using the protective equipment.
- The rescue of persons involved in an accident must be ensured at all times by the workers' own means.
- Before works begin, measures must be taken to ensure that no objects can cause a fall down from the workspace. The area under the workspace (pavement, ...etc.) is to be kept clear and enclosed.
- If after the acceptance of the safety system, renovation work is undertaken in its immediate vicinity, it must be established that this renovation has no impact on the safety of the installed safety system! In case of doubt, the installer or the manufacturer must be consulted to clarify the case.
- It is forbidden to use the system until its inspection and complete or partial replacement, if the system has fulfilled its fall arrest function!
- After being subjected to the stress of fall, then the system may only be used again after a thorough check and a complete or partial replacement. Any use before the checks is forbidden.
- It is prohibited to carry out unauthorized modifications of the fall protections.
- It is prohibited to use the systems as lightning protection systems. The components of the lightning protection must not statically load the systems. The fall protection systems must not be used as air-termination systems; corresponding lightning protection standards must be complied with.
- Never hang loads on the safety system that are not approved in this manual, and never use it as an alpinist suspension point.
- The system is never to be used as alpinist anchoring points. The system shall not be loaded with any further weight different from its original purpose.

- We strongly recommend for the users' safety: The installation, inspection, and maintenance of the fall protection systems should only be carried out by a competent installer qualified to carry out the installation and inspection. This also includes system-related, completed testing. Alternatively, the examination can be carried out by an expert of the authorized authorities or examination institutions.
- A basic tenet of the effective operation of the fall protection anchoring system in the long term is regular maintenance - **at least every 12 months** in the manner prescribed by the manufacturer.
- If the maintenance work is not carried out, is incomplete or not carried out in time, the system may be used exclusively at the responsibility of the owner/operator.
- The timing of inspections recommended by the manufacturer in the instructions of the installed system (in individual cases) may also depend on the local legal requirements, on the frequency of use, and on local conditions (e.g. chemical damage, frequent lightning, etc.).
- The RoofX® system may be extended only through the use of original accessories, developed by the manufacturer of the system. The installation and use of parts or products from other manufacturers, even if their appearance is very similar, is strictly prohibited.
- The installer should make sure that the receiving structure is able to bear the load what comes with the system installation. If there is any doubt, consult with a structural engineer.
- The RoofX® fall protection anchoring system may be installed and used only according to the manufacturer's guidelines in the Technical Manual.
- If the system has fulfilled its fall arrest function, following a fall, the system must be immediately withdrawn from use. An immediate inspection must be performed before the system is used again. The system must be replaced entirely or partially depending on the findings of the inspection.
- If all pages of yearly checks in the Service Book are full, or the Service Book seriously damaged, or the Technical Manual is lost, get in touch with your distributor / dealer.

3.2 Application

- The Technical Manual should be read carefully, and the included manufacturer's notices and instructions must be observed before the use of the system. The Service Book does not replace the Technical Manual. You should thoroughly study the Technical Manual before starting to use the system.
- The minimum free space necessary under the edge is calculated as follows: **Deformation of the anchor device in case of stress + manufacturer's specification of the PPE (Personal Protective Equipment) used, including deflection of the cable + body height + 1m safety margin.**
- For installations higher than 1000 m above sea level, the distance between the posts will decrease by 30%, while the wire-rope sagging will increase by 30%.
- **Cable sag:** The cable sag may not reach higher than 3.0 cm above the roof surface. The lateral mobility of the rope shall be ensured at all times, and shall be checked before each use! E.g.: green roof structure, but applicable to all roof structures. Care must also be taken to ensure that the cable is not tensioned during installation.

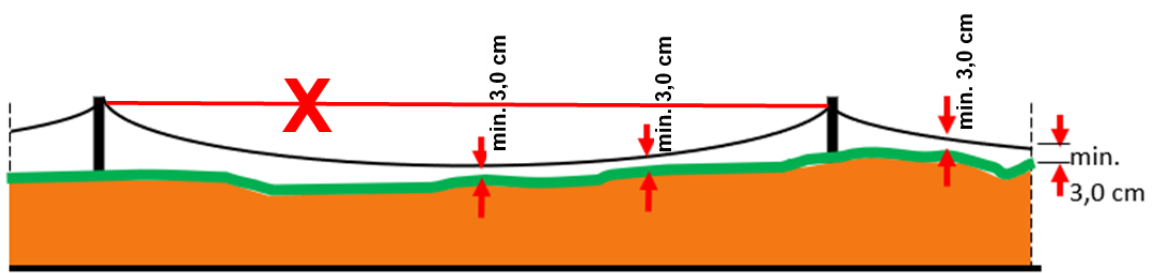

- In heavy snowfall, the roof surface surrounding the fall protection system must be kept clear, so that the snow can not affect the undisturbed functioning of this system.
- Proper use of the individual components, including the PPE must be ensured, since the effectiveness of the fall prevention system is otherwise not guaranteed.
- System checks should be carried out at least once **every 12 months**. Check interval durations depend on relevant regional regulations, system use frequency, as well as local conditions (e.g. chemical hazards).
- Attachment to the fall protection system is completed with a carabiner and must be used with a PPE in accordance with standards EN 361 (safety harness) and EN 363 (fall arrest system).
- If the system is used with a direct connection (a carabiner) or a traveller made by another manufacturer according to EN 362 – as long as the traveller doesn't run through the column head – special care must be taken during the changeover. The distance for the changeover from one rope end to the next rope end shall be max.15 cm.

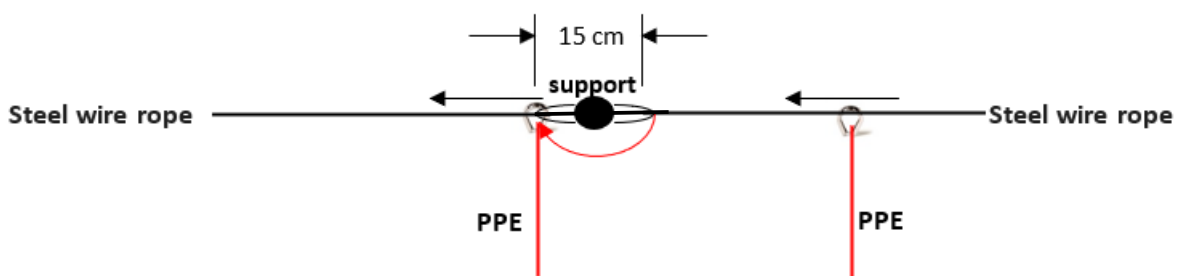

- In case of using personal protective equipment according to EN 360 or EN 365-2 special care must be taken, and the properties of the equipment must be taken into account in the calculations.
- **ATTENTION!** For horizontal use, only such connecting elements can be used which are designed for this purpose and tested for the respective edge type (sharp edges, trapezoidal sheet, steel grids, concrete, etc.).
- The national regulations of the employers' liability insurance association must be observed. In case of unsuitable weather and wind forces exceeding the "usual" level (approx. 5.5 to 8.0 m/s = fresh breeze), fall protection devices must NOT be used. The relevant data should be obtained from a responsible weather service.
- RoofX® systems should only be used in a frosted environment if they have been installed in unfrosted conditions or if at least one unfrosted period has elapsed between installation and first use. If safe use of the system in frost is not guaranteed, it must not be used.
- The fall protection system must not be used by children or pregnant women.
- In the EN795 standard an installation document has been needed since 2012, for every anchoring system. This documentation must include detailed information about the following: location, company carrying out the installation, installer responsible, system installed. Also there must be a Delivery/receipt record completed (it is found in the Service Manual), which verifies that the installation has been performed professionally in accordance with standards. Furthermore, there must be drawn up construction plan, which shows the places of the anchoring points and the steps of installation must be photographed as well. Special care must be taken with elements of the anchoring system which are going to be covered after the installation. If, on a given location, there are separate roof areas and different types of anchoring systems are installed, a distinct documentation must be made for each roof area and each system.

4 Manufacturer's responsibility, warranty

- The Manufacturer's warranty covers only the product failures that were generated during production. In such a case, the manufacturer shall replace faulty or damaged components in the frames of a justified warranty claim. The following are not the subject of a so-called manufacturer's warranty: natural wear and tear, improper use, environmental influences, and complaints resulting from aesthetic changes.
- Because of the unknown site conditions, the manufacturer assumes no responsibility for the warranty about damage caused by diversion from the Technical Manual (improper use, incorrect installation or other reasons).
- A major prerequisite of long-term fall protection system operation is regular maintenance as prescribed by the manufacturer and the standards. Should maintenance steps fail to be executed in due time, then the system can only be used for own risk. Should any damage or accident happen on an unchecked system, the manufacturer's responsibility shall terminate.
- RooFx® systems can be extended using original accessories developed exclusively by the manufacturer. Should any components or products of any other manufacturer be installed or used in the system, manufacturer's responsibility and guarantee terminate immediately.
- Should the system not be installed or assembled by the manufacturer instructions or a contractor authorised for installation, the manufacturer shall accept no claims, other than for faulty products.
- Should a fall occur, the system must be discarded, and it is PROHIBITED to use it any longer! System use can only be resumed after an official interim inspection. In accordance with the inspection, relevant system components or the whole system must be overhauled or replaced. As long as the distraint or the inspection is not carried out, the manufacturer is not liable for the use of the system any longer.
- Manufacturer shall cease to take any further warranty for the system in the following cases: damage and alterations due to environmental conditions, normal wear and tear, misuse and an aesthetic alteration.
- Particular attention has been paid to producing these instructions. However it is not possible to show all the potential versions and these instructions do not therefore claim to be exhaustive. DIADEM® APP GmbH shall not be liable for any usage or application error, which may arise from the misinterpretation of the methods shown here.

4.1 General terms of warranty

For the RoofX® fall protection anchoring systems range, we undertake a General Manufacturer's warranty of **60 months**, valid from the day of the sale of the product by Manufacturer.

The warranty does not cover:

- Any loss of time, inconvenience, administrative costs or any other consequential damages suffered by the owner/maintainer as a consequence of a malfunction under warranty.
- Repair or replacement of spare parts, due to the following causes:
 - Wear and tear from normal use.
 - Damage or alteration due to negligence or improper use.
 - Activated fall arrest function, requiring replacement or any modification of the system, or of any part thereof, without the manufacturer's approval.
- Any modification of the system, or of any part thereof, without the manufacturer's approval.
- Uses not intended or expressly prohibited by the manufacturer.
- Damage caused by the user's physical condition or health (with special regard to the weight limit: 130kg/person) and thus improper use.
- Damage caused by the owner/maintainer's failure to adequately maintain, service or repair any part of the system.
- Other causes, such as: damage due to extreme environmental impact; natural wear and tear, aesthetic alteration, etc.

Loss of warranty rights, including, among others:

- Damage occurring following incorrect installation of the product, or installation not following the guidelines.
- Loss of function and other faults due to improper use.
- Deterioration, structural damage, loss of function of the installed product due to external impact.
- Loss of function or structural damage due to natural causes (lightning strike, snow, or ice stress, earthquake etc.).
- Evidence of damage caused by unauthorised and/or non-professional repair, mounting, or impact.

4.2 Expected lifetime

The RoofX® safety systems maximum lifetime is **25 years** from the date of correct installation – In case of the intended use, optimal condition, and without any visible damage.

The actual life expectancy - under proper use - is expected to be longer than the specified period if it is not affected by natural wear and tear that influences proper operation. These provisions are based on the current state of the art, and on previous findings and experience.

Although this is not a guarantee, it is an important argument from an economic point of view regarding the expected service life of the system.

A prerequisite for compliance with the specified life expectancy is annual maintenance of the system by qualified personnel in accordance with regulations.

This must be verifiably demonstrated by a complete, detailed registration. For this purpose, it is recommended to use the manufacturer's registration system.

This is another prerequisite for any warranty claims.

If this is not done, the manufacturer shall be relieved from any liabilities. In this case, the liability remains with the executing contractor.

5 System design, and components

5.1 RoofX® Single anchoring points

5.1.1 RoofX®-C Single



Anchor post: RoofX®-C

Properties: Mineral wool thermal insulation
Factory integrated „Thermostop“

Load direction: 360° (horizontal)

Material: Stainless steel 1.4301 (head, foot, body),
IR/SBR elastomeric base (Thermostop)

Load bearing structure: Reinforced concrete C20/25 - C50/60

Standard height: 500 mm

Custom sizes can be ordered (200-1000 mm)

Weight: 2,45 kg

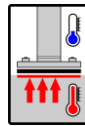

5.1.2 RoofX®-W/T Single

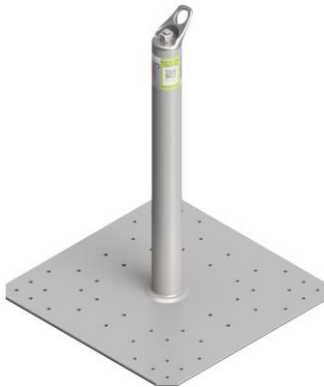

Anchor post: RoofX®-W/T

Properties: Mineral wool thermal insulation
Factory integrated „Thermostop“

Load direction: 360° (horizontal)

Material: Stainless steel 1.4301 (head, foot, body),
IR/SBR elastomeric base (Thermostop)

Fixation: OSB3 sheet min. 22mm
plywood min. 22mm
structural wood min. 22mm
trapezoidal sheet min. 0,75mm

Standard height: 500 mm

Weight: 6,25 kg

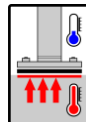

5.1.3 RoofX®-EVO Single



- Anchor post:** RoofX®-EVO
Properties: Mineral wool thermal insulation
 Factory integrated „Thermostop“
Load direction: 360° (horizontal)
Material: Stainless steel 1.4408 (foot)
 Stainless steel 1.4301 (head plate)
 Stainless steel steel pipe 1.4301
 threaded rod M12, washer M12
 screw thread M12
 IR/SBR Elastomerbasis (Thermostop)
Load bearing structure: Reinforced concrete C20/25 - C50/60
Standard height: 500 mm
Custom sizes can be ordered (200-600 mm)
Weight: 2,7 kg

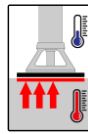

5.1.4 RoofX®-ISOFIX Single



- Anchor post:** RoofX® -ISOFIX
Properties: Mineral wool thermal insulation
 Factory integrated „Thermostop“
Load direction: 360° (horizontal)
Material: Stainless steel 1.4408 - foot, head
 GRP Pipe (Glass Fiber Reinforced)
 Plastic - plastic insert
 Threaded rod M12, Screw thread M12
 IR/SBR Elastomerbasis (Thermostop)
Load bearing structure: Reinforced concrete C20/25 - C50/60
Standard height: 500 mm
Custom sizes can be ordered (200-500 mm)
Weight: 2 kg

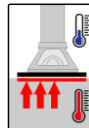

5.1.5 RoofX® Single / Anchor point components



DS Single SEAT head Kit
Product number: 130939
Material: Stainless steel 1.4408 cast
Attached: M12 nut, spring washer, spacers



Ring nut (Optional)
Product No.: 100741
Material: M12, 8. Strength class/size

5.2 RoofX® Glide Line system

5.2.1 RoofX®-C Glide



Anchor post: RoofX®-C
Properties: Mineral wool thermal insulation
 Factory integrated „Thermostop“
Load direction: 360° (horizontal)
Material: Stainless steel 1.4404 (head),
 Stainless steel 1.4301 (foot, body),
 IR/SBR elastomeric base (Thermostop)
Fixation: Reinforced concrete C20/25 - C50/60
Min. distance of posts: 0,5 m
Optimal distance of posts: 10 m (*max. 15 m*)
Standard height: 500 mm
Custom sizes can be ordered (200-1000 mm)
Weight: 2,53 kg

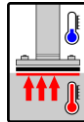

5.2.2 RoofX®-W/T Glide

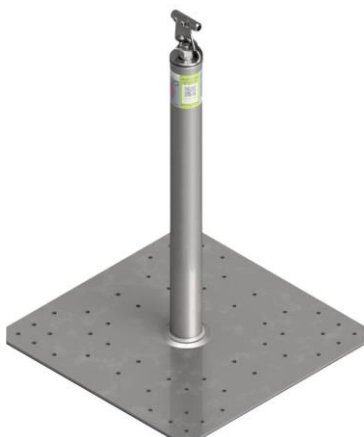

Anchor post: RoofX®-W/T
Properties: Mineral wool thermal insulation
 Factory integrated „Thermostop“
Load direction: 360° (horizontal)
Material: Stainless steel 1.4408 (head),
 Stainless steel 1.4301 (foot, body),
 IR/SBR elastomeric base (Thermostop)
Fixation: OSB3 sheet min. 22mm
 plywood min. 22mm
 structural wood min. 22mm
 trapezoidal sheet min. 0,75mm
Min. distance of posts: 0,5 m
Optimal distance of posts: 8 m (*max. 10 m*)
Standard height: 500 mm
Weight: 6,33 kg

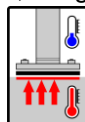

5.2.3 RoofX® -EVO Glide



Anchor post: RoofX®-EVO
Properties: Mineral wool thermal insulation
 Factory integrated „Thermostop“
Load direction: 360° (horizontal)
Material: Stainless steel 1.4408 (foot)
 Stainless steel 1.4301 (head plate)
 Stainless steel steel pipe 1.4301
 threaded rod M12, washer M12
 screw thread M12
 IR/SBR Elastomerbasis (Thermostop)
Fixation: Reinforced concrete C20/25 - C50/60
Min. distance of posts: 0,5 m
Optimal distance of posts: 10 m (max. 15 m)
Standard height: 500 mm
Custom sizes can be ordered (200-600 mm)

Weight: 2,7 kg

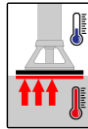

5.2.4 RoofX® -ISOFIX Glide



Anchor post: RoofX®-ISOFIX
Properties: Mineral wool thermal insulation
 Factory integrated „Thermostop“
Load direction: 360° (horizontal)
Material: Stainless steel 1.4408 (foot, head plate)
 GRP Pipe (Glass Fiber Reinforced)
 Plastic - plastic insert
 Threaded rod M12, Screw thread M12
 IR/SBR Elastomerbasis (Thermostop)
Fixation: Reinforced concrete C20/25 - C50/60
Min. distance of posts: 0,5 m
Optimal distance of posts: 10 m (max. 15 m)
Standard height: 500 mm
Custom sizes can be ordered (200-500 mm)

Weight: 2 kg

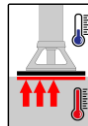

5.2.5 RoofX® Glide / Line system components:



DiaSafe 21 head Kit

Product No.: 100595

Material: Cast stainless steel 1.4408 / surface polished

Attached: M12 nut,
M12 spring washer
M8 x 8 mm set screw



DS Stainless steel anchoring wire-rope

Product No.: 100268

Material: Stainless steel 1.4404

Diameter: Ø 8 mm (7 × 19)

Tensile strength: F = 33,4 kN



DiaSafe-Loop

Product No.: 100596

Material: Cast stainless steel 1.4408 polished

Size: 29 x 29 x 29 mm



DS DiaGlider-Fix (without Carabiner)

Product No.: 100471

Material: Stainless steel 1.4542

Application: Placed on the wire, not detachable.



DS Holder head Kit (for system beginning, ending and T-branching)

Product No.: 130942

Material: Stainless steel 1.4301

Attached: M12 nut, spring washer



DS Cable Thimble

Product No.: 100279

Material: Stainless steel 1.4404

Size: 58 x 38 mm



DS Wire-rope terminating shrinkable tube

Product No.: 090845

Size: Ø9 mm

5.2.6 RoofX® Glide / Line system optional components:



DS Swaged turn buckle (in case of closed system)

Product No.: 100356

Material: Stainless steel 1.4404

Adjustable length: 325 - 400 mm



MAS HA4 rope

Material: 16 mm twisted rope, polyester

Product No.:	130981	13 m	with 1 carabiner
	130982	16 m	with 2 carabiner
	130983	20 m	with 2 carabiner
	130984	23 m	with 2 carabiner
	130985	25 m	with 3 carabiner
	130986	30 m	with 3 carabiner

5.3 Fastening elements, accessories

5.3.1 RoofX[®]-C fastening elements (concrete)



M12x120 12/20 A4 anchor Stainless steel
Product No.: 130911
RoofX[®]-C Anchor-Kit for concrete (3 pcs.)
RoofX[®]-EVO und ISOFIX Anchor-Kit for concrete (2 pcs.)

5.3.2 RoofX[®]-W/T fastening elements (wood)



RoofX[®]-W/T Screw Kit for OSB sheet / wood / fiber board
Product No.: 130938
JT3-X-2-6,0x36 drilling screw stainless steel, bi-metal (28 pcs.)

5.3.3 RoofX[®]-W/T fastening elements, trapezoidal sheet



RoofX[®]-W/T Screw Kit for trapezoidal sheet fixing
Product No.: 130935
B21 / LD3T 4.8x25 drilling screw (24 pcs)



MNI-10-12 Screw Insulator Screw separator
RoofX[®]-W/T Screw insulators are required for installing on trapezoidal sheets! (24 pcs.)



5.3.4 Insulating collar



Product No.: 130914
RoofX[®]-C and RoofX[®]-W/T insulating collar
Types: Bitumen, EPDM



Product No.: 130915
RoofX[®]-C and RoofX[®]-W/T insulating collar
Types: PVC

5.3.5 Recommended karabiner to connect our systems



Applied standard: EN362:2013
Max. diameter: ∅ 12 mm



6 Load bearing structure

6.1 Anchor height and roof layer build-up

The column height is specified on the designer's execution plan.

- The minimum column height must be: layer thickness i of the roof structure + minimum overhang of 15 cm.
- The max. column height is not determined, as it depends on the respective column distances, the max. temperature difference within a year (max. plus degrees and max. minus degrees).

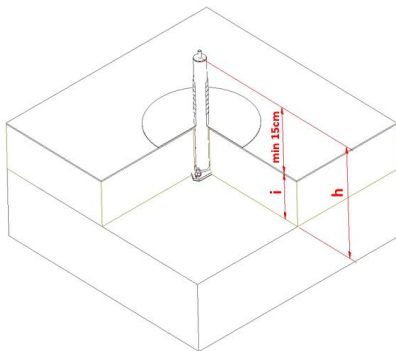

As a rule of thumb, with a layer thickness of 160 mm and a maximum column spacing of 10 m, you can use a 500 mm column. Drawing not to scale.

6.2 Mounting on the load bearing structure

6.2.1 RoofX®-C, RoofX® EVO és ISOFIX

Applied reinforced concrete strength class:

Applied standard:

Minimal roof size:

Minimal reinforced concrete structure thickness:

Fixing type:

anchor bolt

C20/25 - C50/60

EN 206-1/A2

min. 1,0m x 1,0m

min. 16 cm

RoofX®-C: mechanical, 3 pcs. anchor bolt

RoofX®-EVO, ISOFIX: mechanical, 2 pcs.

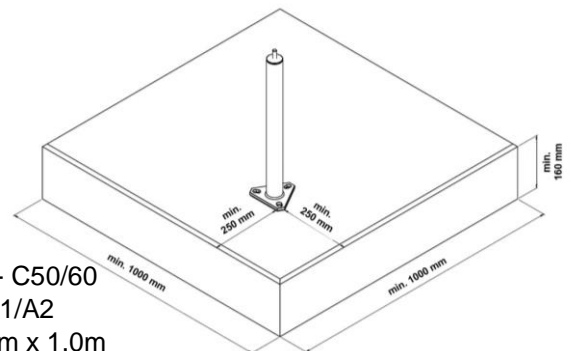

The correct function can be provided only with the recommended fixing kits.

6.2.2 RoofX®-W/T applied to wood

Applied wood quality:

Applied standard:

Minimal roof size:

Wood thickness:

Roof rafter spacing:

Number of carriers under the sheet:

Fixing type:

min. OSB3, min. C24

EN 300, EN 338, EN 14081-1:2016+A1

min. 1,0m x 1,0m

min. 22 mm

max. 1,0 m

min. 3 pcs.

mechanical, with self-drilling screw

The correct function can be provided only with the recommended fixing kits.

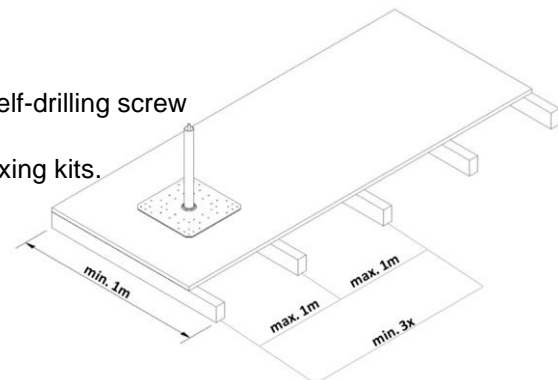

6.2.3 RoofX®-W/T applied to trapezoidal sheet

Applied trapezoidal sheet strength class:	S280
Applied standard:	EN 10346
Minimal roof size:	min. 3,0 m x 1,0 m
Trapezoidal sheet thickness:	min. 0,75 mm
Fixing type:	mechanical, with self-drilling screw

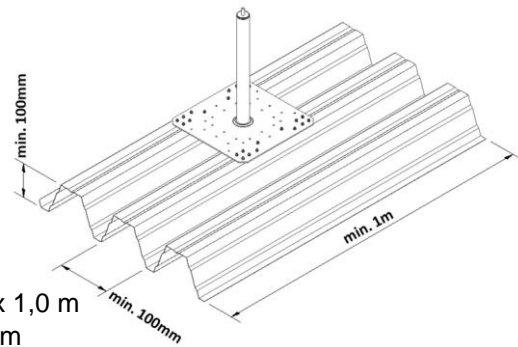

The correct function can be provided only with the recommended fixing kits.

6.2.4 Special case for fastening with 2 or 1 anchor (RoofX®-C)

The standard installation guide remains, it is the general one that must be followed at all times, indicating that the post should be fastened with three dowels. In certain cases, however, it can be fastened with 2 / 1 anchors.

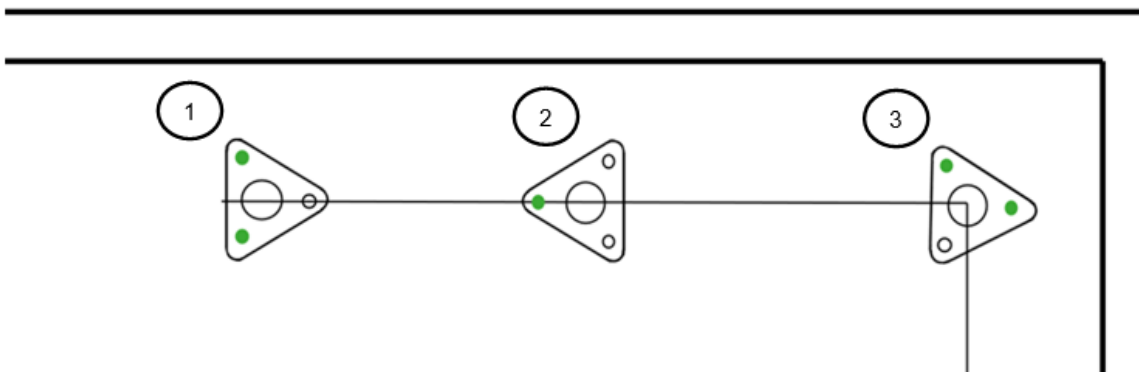

Each corner, start, and end post requires 2 anchors bolts per anchor post. Only 1 anchor bolt is needed for the intermediate post.

(The green dots mean the anchors).

The rope line defined by the bolt anchors of the start and end posts must always run according to the above figure in such a way that the hole in the base plate that remains without a fastener (dowel, anchor, bolt) always points in the direction of the next intermediate post.

For the corner posts, make sure that the two bolt anchors are aligned laterally to the rope axis in the possible fall direction. The intermediate posts are fixed so that the bolt anchor and the center of the posts are in line with the rope axis.

7 Information on system installation and usage

- The system guarantees full-scale safety for the user, regardless of the sag of the wire.
- The sag of the wire may change during the lifetime of the system, e.g. due to the mounting actions, thermal expansion or other dynamic effects. It is important that the RoofX® systems are not preloaded systems, the wire does not need to be entirely tight, on the contrary, overtight wires



originating from the incorrectly adjusted sag of the wire disadvantageously affect the efficiency and durability of the anchoring system.

- If posts of the system are distorted due to the incorrect wire tension during or after the installation, it means that the system was overstretched.
- Such bending of a post due to mounting, thermal expansion or other dynamic effects means solely an aesthetic change to the system, it cannot be subjected to manufacturer's warranty procedure.
- The system is capable to accomplish its function even in the above cases.
- When using according to the respective intended use, the fixing element of the post head of the system can be used - released and then fixed again - safely so many times on the occasion of the mandatory check before maintenance, inspection and use, until no tear of a filament on the wire can be experienced and the clamping bolt can be operated as intended.

8 System installation and annual inspection information

8.1 System installation and annual inspection

- For the commissioning of the system, the Service Manual and the handover protocol shall be completed in compliance with the test criteria. The validating sticker shall be placed on the control label.
- The annual inspection shall be documented in writing. The test criteria and detailed information are included in the Service Manual. Based on the international guidelines and the manufacturer's instructions, the inspection shall be performed without test load.

8.2 Information regarding required free fall height

To appropriately fulfil the fall arresting function of the system it is required to consider the correct free fall height both for planning and before being put into service. To consider this, assistance is provided by the respective existing provisions.

Warning!

The system shall not provide a fall arrest function if the free fall height is below the min. 6,25 m. Displacement of the anchorage point and elongation of the safety rope must be taken into account in all cases.

9 Documentation

The manufacturer provides documentation for each **RoofX**[®] system attached and in digital, downloadable form. The installed falling arrest system can be registered on the **DIADEM**[®] **Online** registration interface. The Installation protocol is prepared during registration.

Parts of the documentation:

- Technical Manual (printed or downloadable)
- Installation Guide (printed or downloadable)
- Service Manual (furnished with individual serial number): (printed)
 - Handover protocol
 - Checking protocol
 - Validating decal
- Control label (printed)

At the annual inspection, the expert performing the inspection is obliged to place the sticker validating the appropriate state of the installed fall arresting system on the control label of the system.

Warning!

In lack of a validly filled and logged Service Manual and/or Online System Registration the state of the system becomes uncontrolled and its functionality becomes uncontrollable. This completely excludes the Manufacturer's responsibility for eventual damages, faults or injuries.

10 Technical data

Maximum deflection and forces (Temperature: 20 °C)

Sufficient clearance under the usage area shall be ensured in any case! Depending on the length of wire the displacement may highly deviate from the data specified by the manufacturer.

System	Type	Test	Deflection [mm]	Max. Force [kN]	System build-up (Type + height)
RoofX®-C	Single	Dynamic	5	12,15	Single 20
RoofX®-C	Single	Dynamic	412	6,66	Single 50
RoofX®-C	Single	Dynamic	900	10,84	Single 100
RoofX®-C	Glide	Dynamic	1725	6,54	Glide 50 + DiaSafe Ballasted (8 m LINE)
RoofX®-C	Glide	Dynamic	2287	6,143	Glide 50 (15 m LINE)
RoofX®-C	Glide	Dynamic	1486	6,118	Glide 20 (15 m LINE)
RoofX®-W/T	Glide	Dynamic	2235	11,58	Glide 50 (10 m LINE)
RoofX®-W	Single	Dynamic	458	10,68	Single 50
RoofX®-T	Single	Dynamic	482	10,85	Single 50
RoofX®-C	Single	Static		23,94	Single 20
RoofX®-C	Glide	Static		17,81 / 17,45	Glide 50 (15 m LINE)
RoofX®-W	Single	Static		21,00	Single 50
RoofX®-T	Single	Static		21,61	Single 50
RoofX® EVO	Single	Dynamic	172	11,69	RoofX EVO 20R
RoofX® EVO	Single	Dynamic	569	15,54	RoofX EVO 60R
RoofX® EVO	Single	Static		44,67	RoofX EVO 20R
RoofX® EVO	Single	Static		45,75	RoofX Evo 60R
RoofX® ISOFIX	Single	Dynamic	158	17,83	RoofX ISOFIX 20
RoofX® ISOFIX	Single	Dynamic	428	17,17	RoofX ISOFIX 50
RoofX® ISOFIX	Single	Static		43,08	RoofX ISOFIX 20
RoofX® ISOFIX	Single	Static		44,88	RoofX ISOFIX 50

11 Disposal

Do not dispose of the used safety system in the house waste. Local regulations should be followed in all cases.

12 Manufacturer, certification

The **RoofX®** fall protection systems have been tested and certified by TÜV Austria Services GmbH.



Zertifikat
Certificate

Nr.: 1832-1907-PSA19-022-Z
Baumusterprüfbescheinigung

Hersteller: APP Kft.
Fehérvári út 75
H - 9028 Győr

Produkt: Persönliche Absturzsicherungs- Anschlagvorrichtungen Typ A/C
Personal fall protection equipment - Anchor devices type A/C

Typ: RoofX®-C
Type:

Beschreibungen: Zulässige Varianten - Siehe Anhang
Description: Valid types - see annex

Prüfgrundlagen: ÖNORM EN 795:2012 (ident EN 795:2012)
CEMTE 16416:2013
ÖNORM EN 365:2004 (ident EN 365:2004)

Bemerkungen: Siehe Anhang
Remarks: See annex

Hiermit bestätigt die TÜV AUSTRIA SERVICES GMBH, dass das oben angeführte Produkt den grundlegenden Sicherheitsanforderungen entspricht. Grundlage dieses Zertifikates ist das zur Prüfung und Zertifizierung vorgelegte Prüfmuster und die technische Dokumentation.
Hereby TÜV AUSTRIA SERVICES GMBH confirms that the above mentioned product meets the essential safety requirements. The certificate is based on the test specimen and the technical documentation subjected to the test and the certification.

Vorgängerdokument / former document
Datum / date

01.07.2019
Datum
01.07.2019
Date

Ing. Georg Götschlich
Geprüft / examined

Dipl.-Ing. Georg Sönnag
Freigegeben / released

30.06.2024
Gültig bis
valid till

TÜV AUSTRIA
SERVICES GMBH
Deutschbühlle 10
A-1230 Wien
Firmenbuchnummer
08987184

Bescheinigung
Certificate

Nr.: 1844-1907-PSA19-023-Z
Baumusterprüfbescheinigung

Hersteller: APP Kft.
Fehérvári út 75
H - 9028 Győr

Produkt: Persönliche Absturzsicherungs- Anschlagvorrichtungen Typ A/C
Personal fall protection equipment - Anchor devices type A/C

Typ: „RoofX®-WIT“
Type:

Beschreibungen: Zulässige Varianten - Siehe Anhang
Description: Valid types - see annex

Prüfgrundlagen: ÖNORM EN 795:2012 (ident EN 795:2012)
CEMTE 16416:2013
ÖNORM EN 365:2004 (ident EN 365:2004)

Bemerkungen: Siehe Anhang
Remarks: See annex

Hiermit bestätigt die TÜV AUSTRIA SERVICES GMBH, dass das oben angeführte Produkt den grundlegenden Sicherheitsanforderungen entspricht. Grundlage dieses Zertifikates ist das zur Prüfung und Zertifizierung vorgelegte Prüfmuster und die technische Dokumentation.
Hereby TÜV AUSTRIA SERVICES GMBH confirms that the above mentioned product meets the essential safety requirements. The certificate is based on the test specimen and the technical documentation subjected to the test and the certification.

Vorgängerdokument / former document
Datum / date

17.07.2019
Datum
17.07.2019
Date

Ing. Georg Götschlich
Geprüft / examined

Dipl.-Ing. Georg Sönnag
Freigegeben / released

30.06.2024
Gültig bis
valid till

TÜV AUSTRIA
SERVICES GMBH
Deutschbühlle 10
A-1230 Wien
Firmenbuchnummer
08987184

Baumusterprüfbescheinigung
Certificate

Nr.: 2668-2305-PSA23-024-Z

Hersteller: A.P.P. Kft.
Fehérvári út 75
9028 Győr
Hungary

Produkt: Persönliche Absturzsicherungs- Anschlagvorrichtungen Typ A/C
Personal fall protection equipment - Anchor devices type A/C

Typ: „RoofX®-EVO“ - Einzelschlagpunkt und Systemstütze für ein horizontales
Sicherungsgerüst
"RoofX®-EVO" - Single Anchor Point and System Post for a Horizontal Live System
Type:

Beschreibungen: Zulässige Varianten - Siehe Anhang
Description: Valid types - see annex

Prüfgrundlagen: ÖNORM EN 795:2012 (ident EN 795:2012)
CEMTE 16416:2013
ÖNORM EN 365:2004 (ident EN 365:2004)

Bemerkungen: Siehe Anhang
Remarks: See annex

Hiermit bestätigt die TÜV AUSTRIA SERVICES GMBH, dass das oben angeführte Produkt den grundlegenden Sicherheitsanforderungen entspricht. Grundlage dieses Zertifikates ist das zur Prüfung und Zertifizierung vorgelegte Prüfmuster und die technische Dokumentation.
Hereby TÜV AUSTRIA SERVICES GMBH confirms that the above mentioned product meets the essential safety requirements. The certificate is based on the test specimen and the technical documentation subjected to the test and the certification.

Vorgängerdokument / former document
Datum / date

25.05.2023
Datum
25.05.2023
Date

Dipl.-Ing. Georg Sönnag
Geprüft / Prüfstelle
Examined by / Testing Laboratory

Ing. Georg Götschlich
Freigegeben / Prüfstelle
Approved by / Testing Laboratory

30.04.2028
Gültig bis
valid till

TÜV AUSTRIA
SERVICES GMBH
Deutschbühlle 10
A-1230 Wien
Firmenbuchnummer
08987184

Baumusterprüfbescheinigung
Certificate

Nr.: 2670-2305-PSA23-025-Z

Hersteller: A.P.P. Kft.
Fehérvári út 75
9028 Győr
Hungary

Produkt: Persönliche Absturzsicherungs- Anschlagvorrichtungen Typ A/C
Personal fall protection equipment - Anchor devices type A/C

Typ: „RoofX®-SOFIX“ - Einzelschlagpunkt und Systemstütze für ein horizontales
Sicherungsgerüst
"RoofX®-SOFIX" - Single Anchor Point and System Post for a Horizontal Live System
Type:

Beschreibungen: Zulässige Varianten - Siehe Anhang
Description: Valid types - see annex

Prüfgrundlagen: ÖNORM EN 795:2012 (ident EN 795:2012)
CEMTE 16416:2013
ÖNORM EN 365:2004 (ident EN 365:2004)

Bemerkungen: Siehe Anhang
Remarks: See annex

Hiermit bestätigt die TÜV AUSTRIA SERVICES GMBH, dass das oben angeführte Produkt den grundlegenden Sicherheitsanforderungen entspricht. Grundlage dieses Zertifikates ist das zur Prüfung und Zertifizierung vorgelegte Prüfmuster und die technische Dokumentation.
Hereby TÜV AUSTRIA SERVICES GMBH confirms that the above mentioned product meets the essential safety requirements. The certificate is based on the test specimen and the technical documentation subjected to the test and the certification.

Vorgängerdokument / former document
Datum / date

25.05.2023
Datum
25.05.2023
Date

Dipl.-Ing. Georg Sönnag
Geprüft / Prüfstelle
Examined by / Testing Laboratory

Ing. Georg Götschlich
Freigegeben / Prüfstelle
Approved by / Testing Laboratory

30.04.2028
Gültig bis
valid till

TÜV AUSTRIA
SERVICES GMBH
Deutschbühlle 10
A-1230 Wien
Firmenbuchnummer
08987184

Copyright:
DIADEM®, **DiaSafe®** and **RoofX®** are registered trademarks! This technical manual is the intellectual property of the manufacturer, the use of its content in any form for business purpose, without the previous authorization of the manufacturer is strictly forbidden.

Manufacturer and distributor of the RoofX® and DiaSafe® systems:

A.P.P. Kft.
H-9028 Győr
Fehérvári út 75.
T: +36 96 512 910

APP Dachgarten GmbH
Jurastrasse 21
D-85049 Ingolstadt
T: +49 841 370 9496

Diadem CH AG
Riedstrasse 7.
CH-6330 Cham
+41 79 516 20 62

www.diadem.com

www.grundach.com
info@diadem.com

www.diadem.ch